



# THERMAL LIQUID HEATER LOW NO<sub>x</sub> METAL FIBER BURNER

G---R(L)HT Models, Bent Steel Liquid Tube Furnace  
672,000 - 2,500,000 BTUH Gas Fired

## THE PARKER DESIGN

The Parker liquid tube design offers an extremely efficient, reliable heater built for the long term with ease of maintenance. The Parker design offers many advantages. Compare ours to the competition.

## ADVANTAGES

- Sealed combustion chamber offers high efficiencies with low excess air levels.
- Less heat loss due to liquid furnace and sealed combustion chamber design.
- SCAQMD Certified for less than 20ppm NO<sub>x</sub>
- Variable speed blower for electrical energy savings.
- LOW NO<sub>x</sub> heavy duty Metal Fiber Burner.
- Flexible tubes, no thermal shock problems.
- Extra heavy boiler tubes 1-5/16" OD, minimum 0.12" (11GA) heavy thickness steel, built for long term service life.
- Double welded tube bundle. No rolled ferrell fit connections or gaskets. Tube bundle is baffled/ designed to match system flow requirements.
- Factory set tube bundle pass baffling to match system flow.
- Units can go through a 35" door.
- Modular cabinet construction.
- Lighter weight. No refractory.

## Low Cost Operation

The staggered tubing design provides a 10-pass self-baffled heating surface to increase efficiency.

**PARKER BOILER CO.**  
 5930 Bandini Boulevard  
 Los Angeles, CA 90040  
 Tel (323) 727-9800  
 Fax (323) 722-2848  
 www.parkerboiler.com  
 BROCHURE 207WW-L 1D0

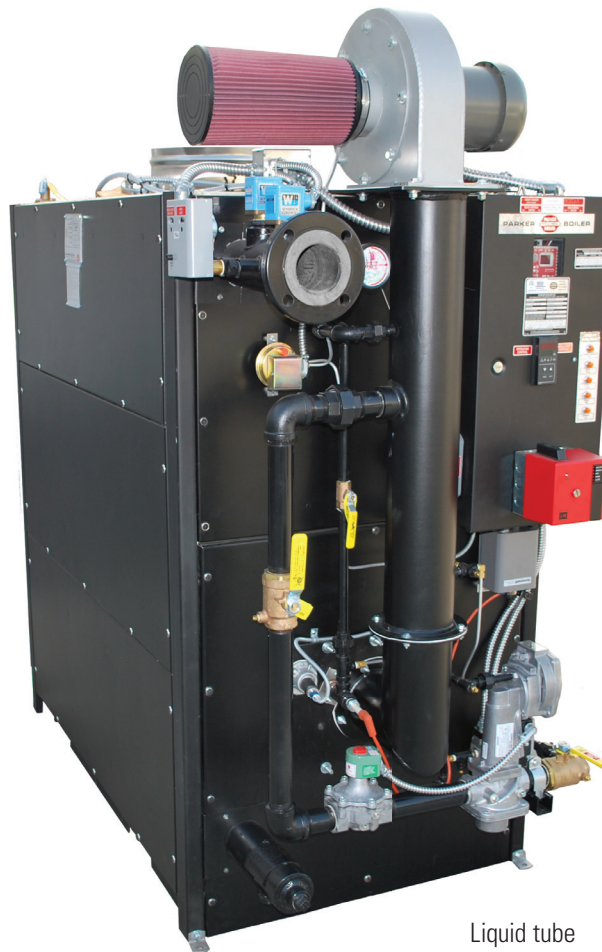

207WW Thermal  
Liquid Heater

Temperatures to 600°F  
Pressures to 125 PSI

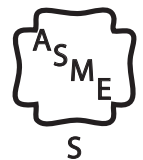

SCAQMD  
Certified to 1146.2



Liquid tube  
Furnace

Metal Fiber  
Burner

## Safety

Our ASME tube bundle is extremely flexible and offers a long life with a 25 year warranty against thermal shock. No Parker Boiler has ever been known to experience an internal explosion.

## Heavy Insulated Cabinet

The cabinet is durably constructed with heavy steel, insulated with high temperature thermal fiber insulation to effectively reduce heat losses to a minimum .

## Codes / Approvals

All Parker Heater Boilers are manufactured in accordance with the ASME Power Boiler Code, registered with the National Board of Boiler and Pressure Vessel inspectors. The boiler burner and controls are prewired, factory tested and comply with ASME CSD-1.

**"Never a Compromise for Quality or Safety"**



## PARKER BOILER THERMAL LIQUID WATER WALL HEATER LOW NO<sub>x</sub> FIRED MODELS G672R(L)HT TO G3120R(L)HT

SPEC. SHEET  
D-207WW-R(L)HT  
1E0

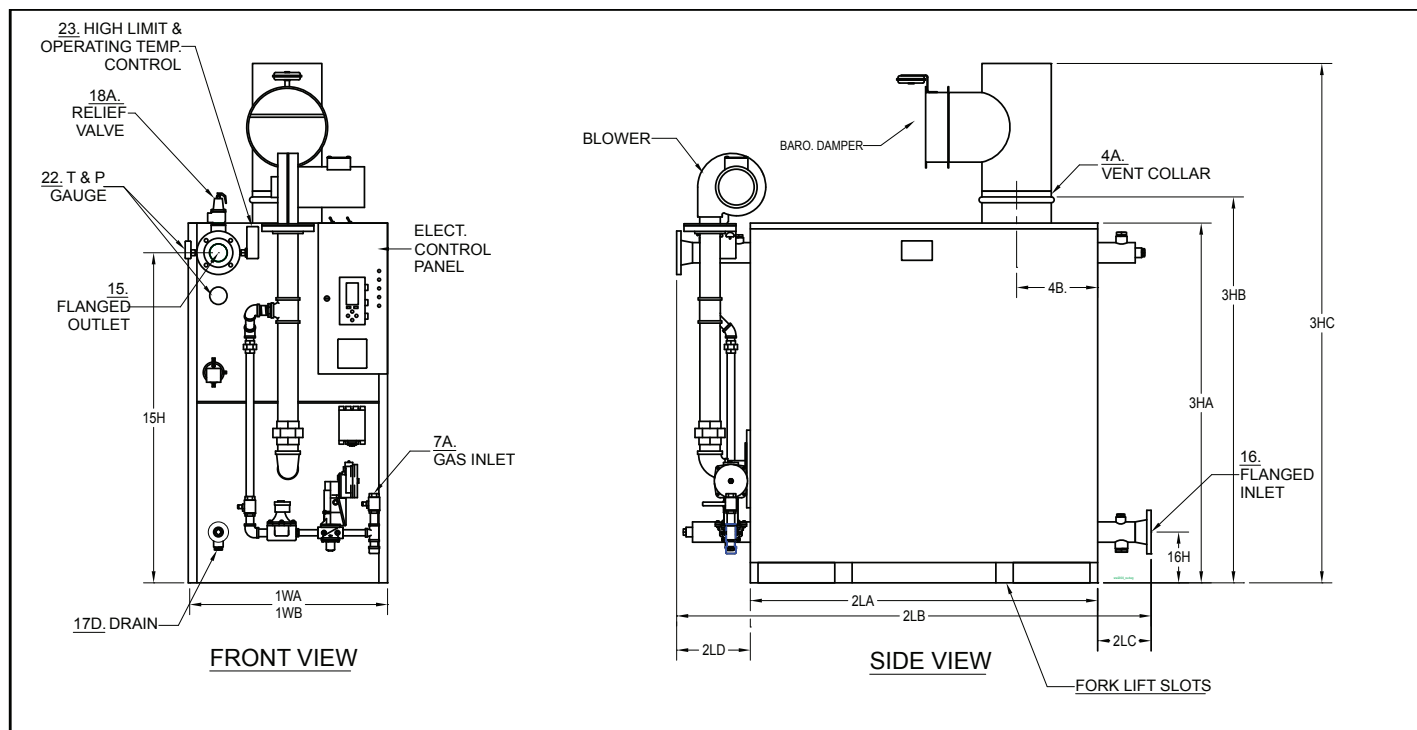

NO.	ITEM	MODEL NO.	G672R(L)HT	G1008R(L)HT	G1536R(L)	G2304R(L)HT	G2640R(L)HT
A	BTU Input	1000's BTU/HR.	672	1008	1536	2000	2500
B	BTU Output	1000's BTU/HR.	537	806	1228	1600	2000
C	Heating Surface	SQ. FT.	93	140	234	294	358
1WA	Width of Cabinet	IN.	35	35	35	35	35
1WB	Width Overall including controls (controls can be removed)	IN.	39	39	39	39	39
2LA	Length of Cabinet	IN.	32	47	68	83	101
2LB	Length Overall	IN.	54-1/2	67-1/2	90	106	123-1/2
2LC	Length of Back Beyond Cabinet	IN.	9-1/2	7-1/2	9	9	8-1/2
2LD	Length of Front Beyond Cabinet	IN.	13	13	13	14	14
3HA	Height of Cabinet	IN.	62	62	62	62	62
3HB	Height with Vent Collar	IN.	66-1/2	66-1/2	66-1/2	66-1/2	66-1/2
3HC	Height Overall Including Barometric Damper	IN.	81	84	90	92	96
4A.	Vent Collar Diameter	IN.	8	10	14	16	18
4B.	Vent Stack Location - From Rear of Boiler Cabinet	IN.	12	17-1/2	23	26	30
7A	Std. Nat. Gas Inlet Size, @ Inlet Supply Pressure; Min: 7" W.C.; Max: 14" W.C.	IN.	1	1	1-1/2	1-1/2	2
7B	Hi Pressure Natural Gas or LP Gas Inlet Size, Supply Pressure 1-5 PSI	IN.	1	1	1-1/2	1-1/2	1-1/2
15 & 16	Inlet & Outlet Size (CL. 150 Flanged)	IN.	3	3	3	3	3
15H	Outlet Height from Floor	IN.	57	57	57	57	57
16H	Inlet Height from Floor	IN.	8-3/4	8-3/4	8-3/4	8-3/4	8-3/4
17D	Drain Line Size Required	IN.	1	1	1	1	1
18AHP	Safety Relief Valve Size - 125 PSI	OUTLET IN.	1-1/2	1-1/2	1-1/2	1-1/2	1-1/2
20A	POWER SPECIFICATIONS	VOLTAGE/PH	115V/1PH				230V/3PH
20B	Controls ( 115V-1Ph-60Hz)	AMPS	5 AMPS				
21	Blower HP	HP	1/2	1/2	1	1	2
	Liquid Capacity	GAL.	16	22	35	43	56
	Net Weight of Heater	LBS.	1440	1685	2350	2800	3600
	Crated Shipping Weight of Heater- Approximate	LBS.	1640	1935	2650	3130	4000

Recommended Clearances 48" around all sides. Electrical Panel 30"; 3Ph (36") ; Additional space may be required by Local Codes.

Notes: Due to continuous improvement, specifications are subject to change without notice.

D-207WW-R(L)HT.DWG



**"Never a Compromise for Quality or Safety"**

**PARKER BOILER CO.**  
5930 Bandini Boulevard  
Los Angeles, CA 90040  
Tel (323) 727-9800  
Fax (323) 722-2848  
www.parkerboiler.com

BROCHURE 207WW-L 1D0