

STYLE GT-A

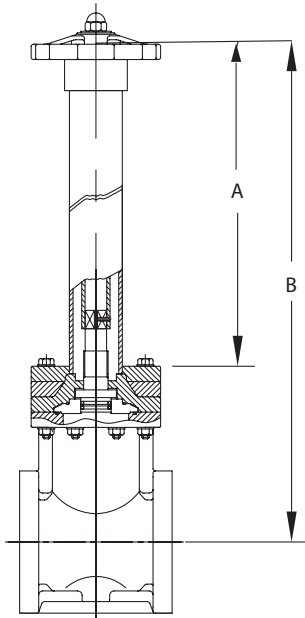

STYLE GT-B

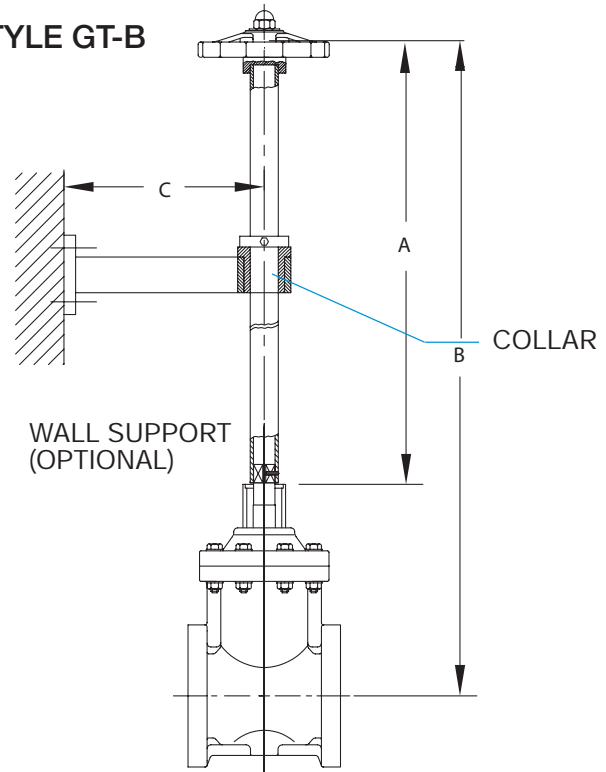

Please use **Stem Extension Work Sheet on Page 20** when ordering any stem extension

All Stem Extension tolerances +/- 1 inch

Two-piece Stem Housing

For submerged or buried applications. PVC housing protects stem extensions from aggressive environments. Stems are available in carbon steel with baked powder epoxy coating, stainless steel (303 and 316, etc.)

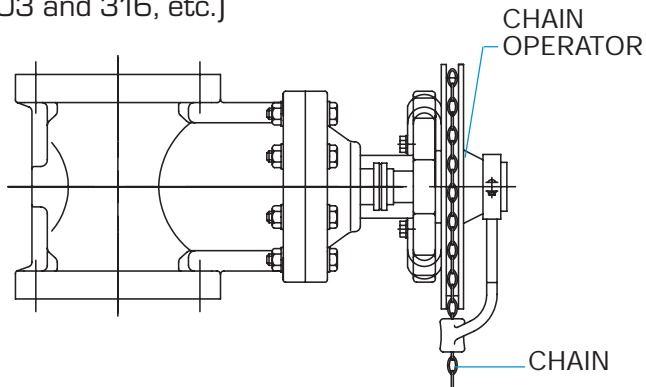

Chain Operator

For overhead, out-of-reach locations. The valve is operated by pulling on the chain installed on round hand-wheel.

Locking Mechanism

Prevents unauthorized cycling of a valve. Designed to be secured with a padlock. Two designs.

Single Stem Extensions (Non-supported)

Valve handle can be extended away from the valve for out-of-reach locations. Stems come in Carbon Steel with baked powder epoxy coating, stainless steel (303 and 316 etc.)

Option: Wall-support (Patented) and Collar

2" SQUARE OPERATING NUT

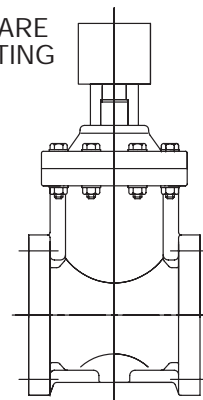

ORIGINAL GATE VALVE

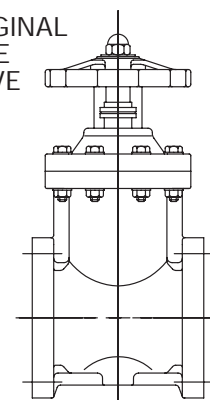

Remote Operating Nuts

2" square configuration on valve stem, replacing the hand-wheel. Used for remote operation of a valve by an extended wrench.

Material: 6061 Aluminum, anodized finish

Special O-Rings

FKM O-rings for corrosive applications.