

UMT SERIES TRAP AND UMTC CONNECTOR

### APPLICATIONS

- Unit Heaters
- Steam Tracing
- Drip Legs
- Tire Presses
- Cooking Equipment
- Laundry Equipment
- Plating Tanks
- Platen Presses
- Air Vents

### OPTIONS

- SLR - SLR Orifice\*
- ISO - ISO Filled Actuator\*
- SW - Socketweld
- B - Blowdown Valve

\*Not available on UMT451T

Canadian Registration # OE1388.6

For information on Big Block UMTVS-BB Connector  
SEE PAGE 116

### OPERATING PRINCIPLE

Thermal actuator is filled at its free length with a liquid having a lower boiling point than water. On start-up, valve is normally open. When steam enters trap, thermal actuator fill vaporizes to a pressure higher than line pressure. This forces valve into seat orifice to prevent any further flow. As condensate collects, it takes heat from thermal actuator,

# LIQUIDATOR 450 SERIES

## UNIVERSAL MOUNT THERMOSTATIC STEAM TRAPS

Pressures to 450 PSIG (31 barg)  
Temperatures to 600°F (316°C)

**Easily Maintained** — Universal two bolt swivel mounting simplifies removal from system. Kits allow flexibility to replace or rebuild.

**Simple Installation** — Stainless mounting block mounts permanently into system. Trap installs via two bolt universal connection.

**Improved Energy Savings** — High efficiency—maximum elimination of air and non-condensibles.

**Temperature Sensitive Actuators** — One moving part. Stainless Steel, fail open, welded actuator for maximum corrosion, thermal and hydraulic shock resistance.

**Hardened Stainless Steel Valve and Seat** — Long life. Lapped as a matched set for water tight seal.

**Easily Maintained** — Can be inspected and serviced without breaking pipe connections.

**Freeze Proof** — Self draining when installed vertically.

**For Superheated Steam Applications** — Because the trap closes at saturated steam temperature, superheated steam cannot reach trap.

**Air Vent** — Efficient steam service air vent when equipped with ISO filled Actuator and installed in air vent location.

**Guaranteed** — Traps are guaranteed against defects in materials or workmanship for three years.

**Positive Shutoff and Long Life** — Integral Stainless Steel Strainer helps prevent debris depositing on valve and seat.

### MODELS

- UMT-TD10L—Low Capacity Trap
- UMT-TD10—Standard Capacity Trap
- UMTC—Standard connector (1/2" & 3/4" only)
- UMTCY-RH—Right Hand Connector w/Y strainer\*
- UMTCY-LH—Left Hand Connector w/Y strainer\*
- UMTVS-BB—Connector with Isolation Valves, Strainer, Blowdown Valve and Test Port

For complete unit, order trap and connector as separate items.

\*Add (-B) for Blowdown Valve.

lowering internal pressure. Line pressure will then compress thermal actuator to open valve and discharge condensate. Valve opening automatically adjusts to load conditions from minimum on very light loads to full lift at maximum load. Restricted orifice in UMT451T (small opening at bottom of valve seat) prevents trap from discharging continuously on light loads such as are encountered on tracer lines.

# LIQUIDATOR 450 SERIES UNIVERSAL MOUNT THERMOSTATIC STEAM TRAPS

## SPECIFICATIONS

Steam trap shall be of balanced pressure design with stainless steel welded actuator capable of discharging condensate within 10°F of saturated temperature. Where greater sensitivity is required, SLR orifice and Sterilizer trim will be available to allow condensate evacuation at or near saturated temperatures. Where subcooling of condensate is desired alternate thermostatic actuator will be available to allow condensate evacuation at or near 40°F below saturated temperatures. Thermostatic actuator shall employ a conical valve lapped in matched sets with the seat ring assuring tight shut off. A minimum of two orifice sizes shall be available allowing for custom capacity sizing. Trap shall be stainless steel bodied suitable for pressures through 450 psig. Trap connection shall be two bolt universal swivel mount. Mounting block shall be stainless steel and available in 1/2" through 1" NPT or socket weld.

## MAXIMUM OPERATING CONDITIONS

Traps with Welded Stainless Actuator  
 PMO: Max. Operating Pressure 450 psig (31 barg)  
 TMO: Max. Operating Temperature 600°F (316°C)

Traps with Welded Stainless Actuator, ISO  
 PMO: Max. Operating Pressure 450 psig (31 barg)  
 TMO: Max. Operating Temperature 600°F (316°C)

All Traps  
 PMA: Max. Allowable Pressure 450 psig (31 barg)  
 TMA: Max. Allowable Temperature 750°F (399°C)

## MATERIALS OF CONSTRUCTION

Body & Cover .....ASTM A351 Grade CF8 (304)  
 Cover Gasket.....304 stainless spiral wound w/graphite fill  
 Actuator .....Welded SS  
 Strainer .....033 perf. 304 Stainless Steel  
 Valve & Seat .....Hardened 416 Stainless Steel  
 Mounting Block .....ASTM A351 Grade CF8 (304)

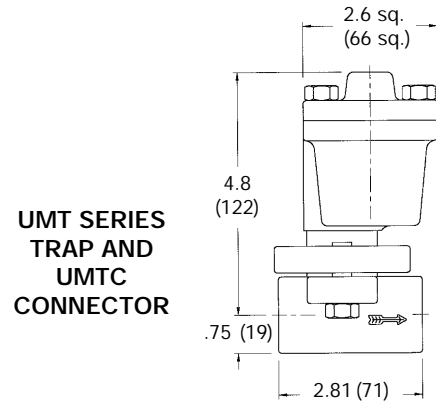

**Connections:**  
 1/2", 3/4" or 1" NPT or socket weld

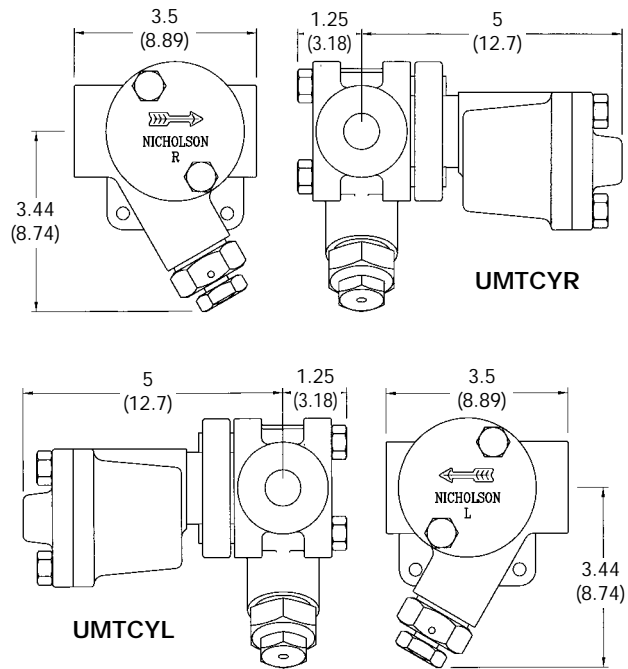

**DIMENSIONS - INCHES (MM)**  
**WEIGHT**  
 TRAP - 3.2 LBS. (1.4 KG)  
 STD. MOUNTING BLOCK - 1.1 LBS. (0.5 KG)  
 Y STRAINER MOUNTING BLOCK - 2.3 LBS. (1.0 KG)

Maximum Capacity—lbs/hr 10°F Below Saturation (Kg/hr 5°C Below Saturation)														
Trap	Orifice Inch (mm)	Differential PSIG (barg)												
		5 (0.34)	10 (0.7)	20 (1.4)	50 (3.4)	100 (6.7)	125 (8.4)	150 (10.1)	200 (13.4)	250 (16.8)	300 <sup>†</sup> (20.1)	350 (24.1)	400 (27.6)	450 (31.0)
UMT451T	5/64 (2)	84 (38)	119 (54)	168 (76)	265 (120)	348 (158)	375 (170)	398 (181)	439 (199)	472 (214)	502 (228)	529 (240)	553 (251)	575 (261)
UMT452T	1/8 (3)	216 (98)	265 (120)	375 (170)	592 (269)	778 (354)	838 (381)	890 (405)	980 (445)	1055 (480)	1121 (510)	1180 (536)	1235 (561)	1284 (584)
UMT453T	1/4 (6)	550 (249)	825 (374)	1210 (549)	1975 (896)	2825 (1281)	3140 (1424)	3425 (1554)	3650 (1656)	3960 (1796)	4100 (1860)	4230 (1919)	4420 (2005)	4600 (2086)

ISO filled Actuator recommended for superheated steam.