

SHARPE[®] VALVES

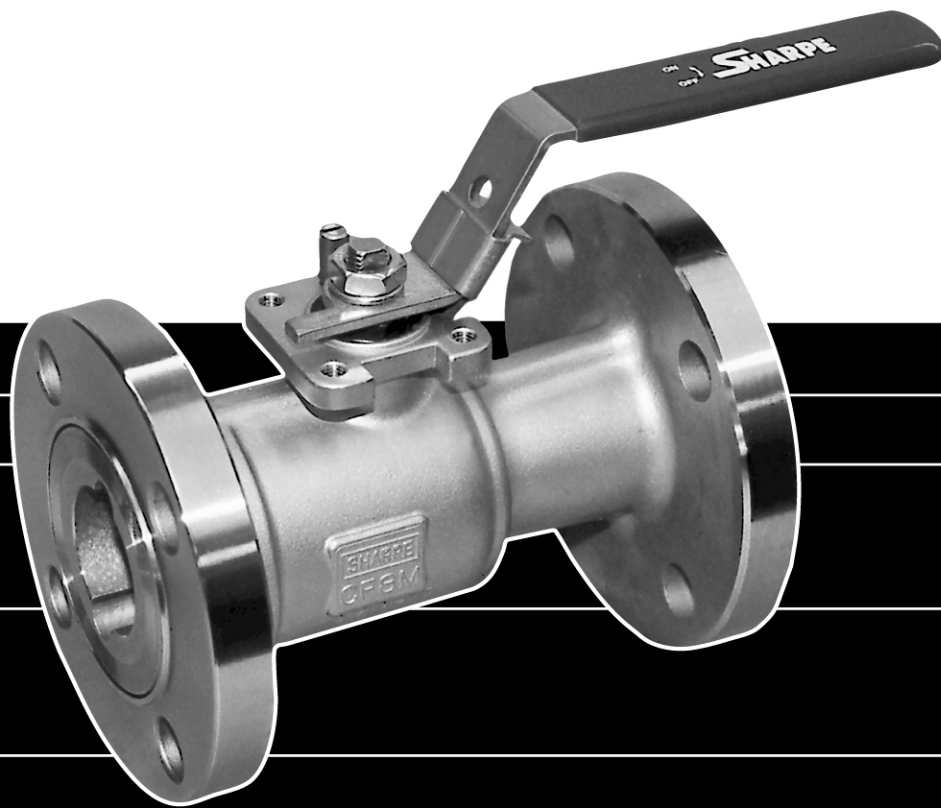

FLANGED STANDARD PORT BALL VALVES

FIRE SAFE SERIES FS54 / CLASS 150/300

SERIES FS54

VALVE PARTS AND IDENTIFICATION

CLASS 150/300
FIRE SAFE API 607 4th EDITION
BLOW OUT PROOF STEM
ANTI-STATIC DEVICE

APPLICABLE STANDARDS	
Shell Wall Thickness	ASME B 16.34
Face to Face Dimensions	ASME B 16.10
Flange Dimensions	ASME B 16.5
Fire Safe	API 607 4th Edition
Tests	ASME B16.34 API 598 (Optional)
Basic Design	ASME B16.34

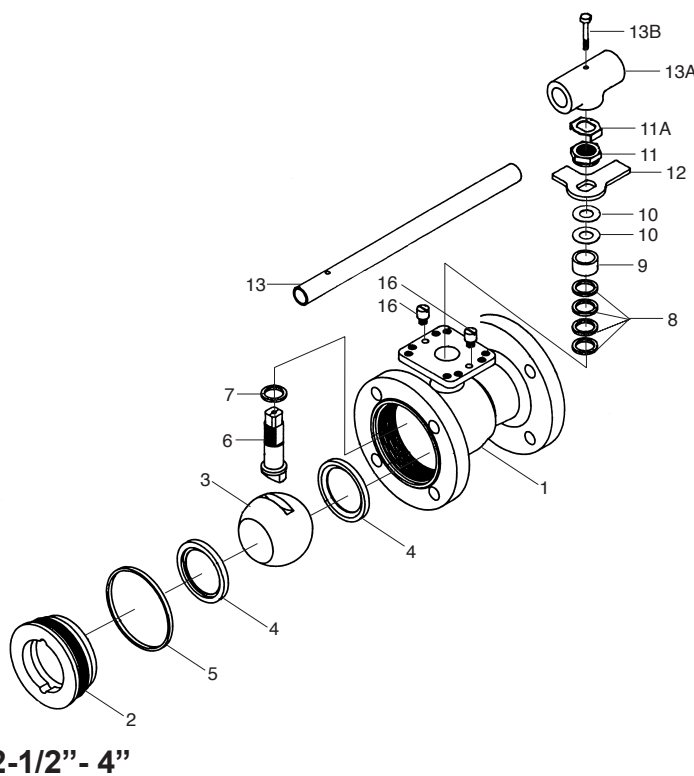
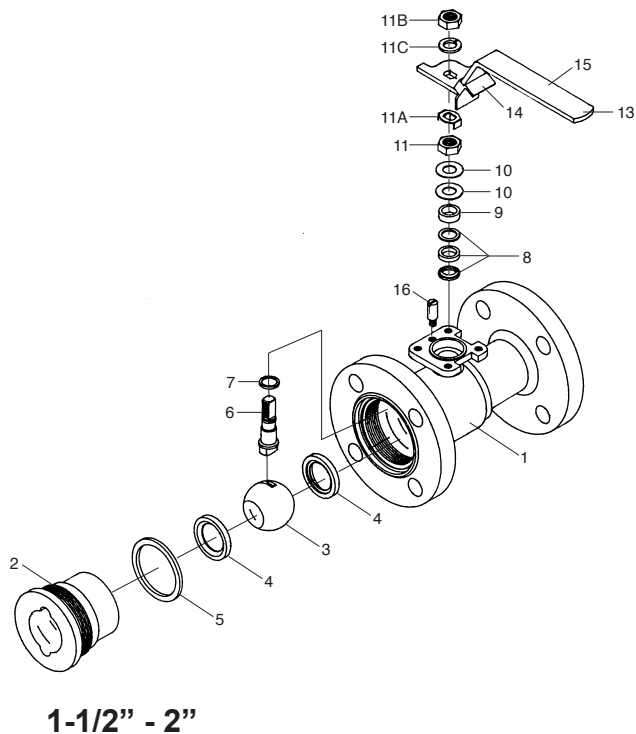

PART NO.	PART	QTY.	MATERIAL
1	Body	1	316 Stainless Steel Carbon Steel Alloy 20 Hastelloy C Monel ASTM A351 CF8M ASTM A216 WCB ASTM A351 CN7M ASTM A494 Gr. CW-12MW ASTM A494 Gr. M35-1
2	End Connector	1	316 Stainless Steel Carbon Steel Alloy 20 Hastelloy C Monel ASTM A351 CF8M ASTM A216 WCB ASTM A351 CN7M ASTM A494 Gr. CW-12MW ASTM A494 Gr. M35-1
3	Ball	1	316 Stainless Steel Alloy 20 Hastelloy C Monel
4	Seat	2	TFE Reinforced TFE NOVA TFM(Super TFE)
5	Body Seal	1	Grafoil
6	Stem	1	316 Stainless Steel Alloy 20 Hastelloy C Monel 17-4PH (Option)
7	Thrust Bearing	2	Reinforced TFE
8	Stem Packing	2	Grafoil
9	Gland Packing	1	304 Stainless Steel
10	Belleville Washer	2/4	304 Stainless Steel
11	Packing Nut	1	304 Stainless Steel

PART NO.	PART	QTY.	MATERIAL
11A	Lock Tab	1	Stainless Steel
11B	Handle Nut (1-1/2"-2")	1	304 Stainless Steel
11C	Lock Washer	1	304 Stainless Steel (1-1/2"-2")
12	Stopper	1	304 Stainless Steel
12A	Snap Ring	1	Stainless Steel (6"-8")
13	Handle 2-1/2"-4" Lockable Handle	1 1	304 Stainless Steel (1-1/2"-2") Galvanized Steel (2-1/2"-4")
13A	Wrench Block	1	Stainless Steel
13B	Hex Head Bolt	1	304 Stainless Steel
14	Locking Device (1-1/2"-2")	1	304 Stainless Steel
15	Sleeve (1-1/2" - 2-1/2")	1	Vinyl
16	Stop Pin (1-1/2"-2")	1	304 Stainless Steel
	(2-1/2"-4")	2	304 Stainless Steel

SERIES FS54 DIMENSIONS

1-1/2" - 2"

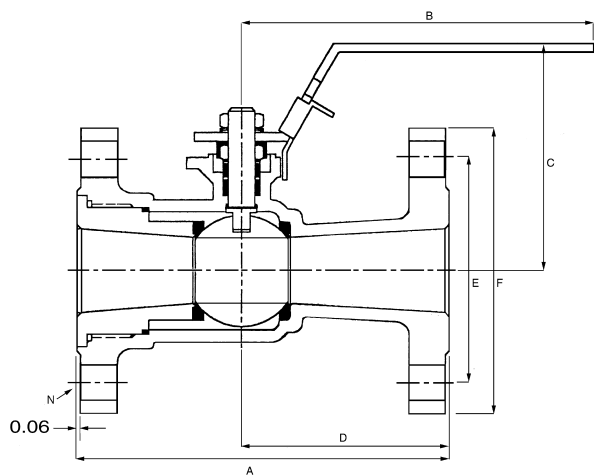

2-1/2" - 4"

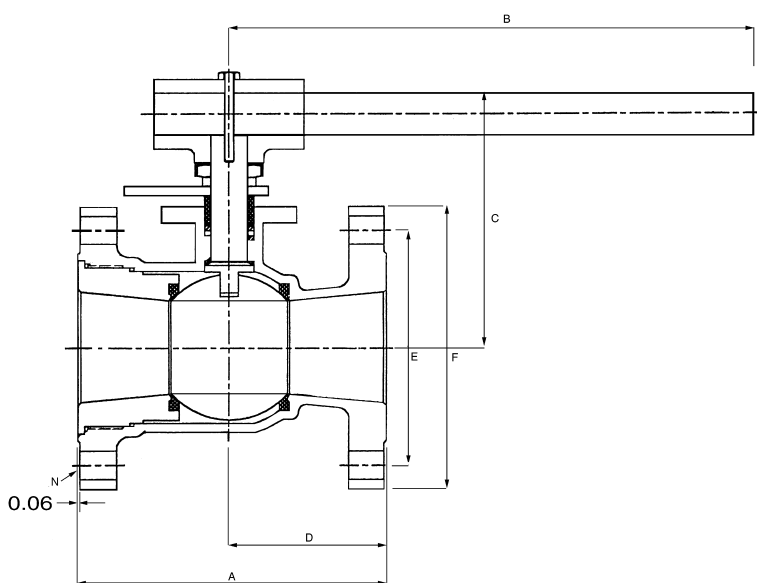

CV* DATA

1-1/2"	82
2"	120
2-1/2"	240
3"	350
4"	720

PORT

1-1/2"	1.25
2"	1.50
2-1/2"	2.00
3"	2.50
4"	3.00

WEIGHT

(lbs.)	150 #	300 #
1-1/2"	16	19
2"	17	21
2-1/2"	26	29
3"	34	48
4"	56	74

*CV: The volume of water in gal./min. that will pass through a given valve with a pressure drop of 1 PSI.

SIZE	A		B		C		D		E		F		N		G		H		I		J		K		W	
CLASS	150	300	150	300	150	300	150	300	150	300	150	300	150	300	150	300	150	300	150	300	150	300	150	300	150	300
1-1/2"	6.50	7.50	9.00	9.00	4.00	4.10	3.68	4.32	3.56	4.50	5.00	6.12	4	4	1.94	1.94	9/16-18 UNF	9/16-18 UNF	.35	.35	.42	.42	.83	.83	M8	M8
2"	7.00	8.50	9.00	9.00	4.50	4.50	4.45	4.92	4.75	5.00	6.00	6.50	4	8	1.94	1.94	9/16-18 UNF	9/16-18 UNF	.35	.35	.42	.42	1.14	1.14	M8	M8
2-1/2"	7.50	9.50	9.00	9.00	6.70	6.70	3.98	5.55	5.50	5.86	7.00	7.50	4	8	2.84	2.84	9/16-18 UNF	9/16-18 UNF	.35	.35	.55	.55	1.14	1.14	M10	M8
3"	8.00	11.12	13.75	14.00	7.00	6.70	4.03	6.77	6.00	6.62	7.48	8.25	4	8	2.84	2.84	1-14 UNS	1-14 UNS	.745	.745	.66	.66	1.83	1.83	M10	M10
4"	9.00	12.00	13.75	14.00	7.70	7.20	4.53	7.12	7.50	7.88	9.01	10.00	8	8	2.84	2.84	1-14 UNS	1-14 UNS	.745	.745	.66	.66	1.83	1.83	M10	M10

1-1/2" - 4"

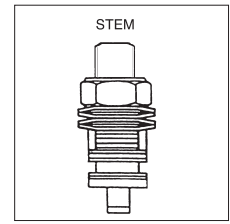
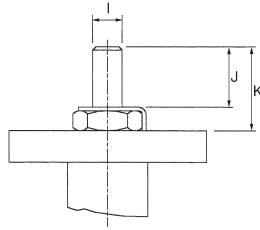
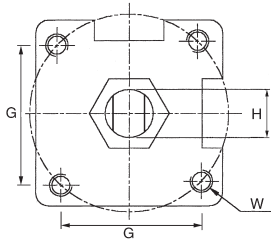

1-1/2" - 4"
STEM ARRANGEMENT

SEAT PRESSURE/TEMPERATURE RATING SERIES FS54

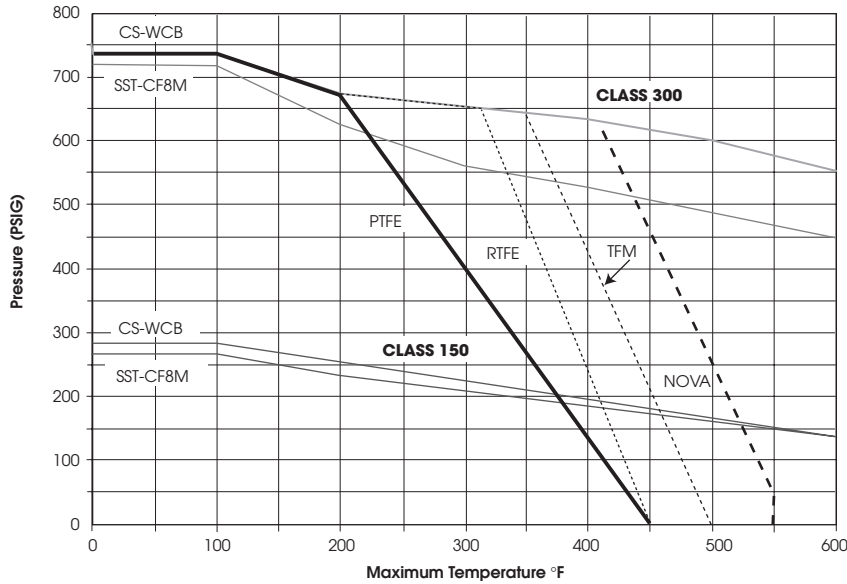

HOW TO ORDER

VALVE SIZE	VALVE SERIES	CLASS	ALLOY	SEATS	OPTIONS
1-1/2" 2" 2-1/2" 3" 4"	FS54	150# = 11 300# = 33	2 = Alloy 20 4 = Carbon Steel 5 = Hastelloy C 6 = Stainless Steel 3 = Monel	T = TFE M = TFM R = Reinforced TFE N = NOVA	X = Oxygen Service OH = Oval Handle F = Fugitive Emissions Certified ANSI S93.00.01 E = Extended Stem L = Lockable Extended Stem D = Leak Detction Stem GO = Gear Operator 7 = 17-4PH Stem A = Nace

2" FS54 11 6 T X

Teflon® is a registered trademark of E.I. DuPont.

SHARPE VALVES

A Division of Smith-Cooper International, LLC

Toll-Free 1-877-7SHARPE

(877) 774-2773

Fax: (708) 562-9250

E-Mail: info@sharpevalves.com

www.sharpevalves.com

1260 Garnet Drive

Northlake, Illinois 60164 U.S.A.