

TYPE N SERIES PILOTS

DIFFERENTIAL PRESSURE PILOTS

CONTROLS 3 to 150 PSIG

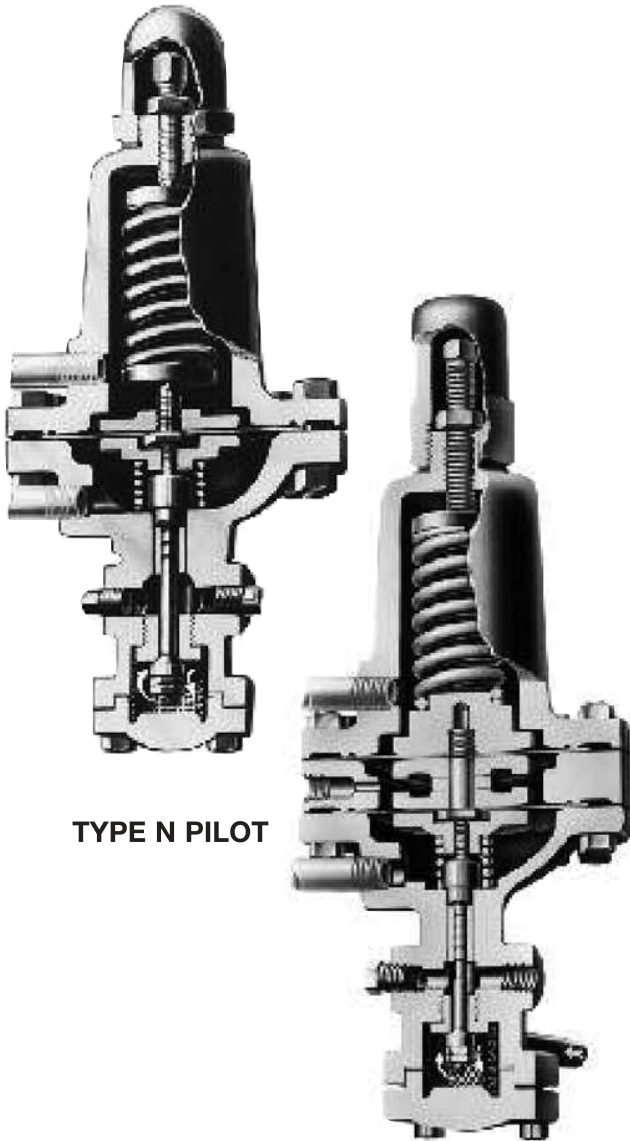

TYPE N PILOT

TYPE N33 PILOT

- Self Contained
- Spring Operated
- Normally Closed
- Packless Construction
- Accurate to ± 1 psi
- Four Adjustable Spring Ranges
- Fluid, Gas & Vapor Applications
- Loading Pressure Supplied by any Fluid
- Accurate Regulation Unaffected by Service Conditions
- Easy In-line Maintenance

OPTIONS

- Integral Mount (for N and N33)

MODELS

- **TYPE N** for delivery pressure at set differential above loading pressure. Available in four spring ranges. Includes integral strainer.
- **TYPE N20** for fixed differential between regulator's inlet pressure and some other lower pressure.
- **TYPE N33** for delivery pressure at set differential above loading pressure where it is essential there be no mixing of two fluids. Ensured by two diaphragms, separated by a vented space. Available in four spring ranges. Includes integral strainer.

APPLICATION DATA

- Boiler Feedwater Makeup
- Steam Atomizing for Oil Burners
- Heat Exchanger to maintain Constant Differential

RATINGS (Maximum Inlet Conditions)

Construction	Pressure PSIG (bar)	Temperature °F (°C)
Cast Iron	250 (17.2)	@ 450 (232)
Cast Steel	600 (41.4)	@ 750 (400)

SPRING PRESSURE RANGES (PSIG)

3-20	10-100
5-50	20-150

Canadian Registration # OC 0591.9C

SIZING INFO
PAGE 116

TYPICAL CONFIGURATIONS

PRESSURE REDUCINGTYPE EN

PRESSURE REDUCINGTYPE E2N

PRESSURE REDUCINGTYPE E5N

TYPE N SERIES PILOTS

DIFFERENTIAL PRESSURE PILOTS

SPECIFICATION

The Pilot shall be separate from the main valve and connected to it with a male union. The Pilot shall have packless construction. The Pilot shall be interchangeable on all sizes of main valves.

MATERIALS OF CONSTRUCTION

Body, Cast Iron	ASTM A126 CI B
Body, Cast Steel	ASTM A216 GR. WCB
Stem	303 St. Stl. ASTM A582 COND A
Disc	440 St. St. ASTM A276 COND A
Seat	420 St. Stl ASTM A276 COND A
Gasket	Non-Asbestos
Diaphragm	301 St. Stl. MIL-5-5059C
Spring	Inconel

TYPE N DIFFERENTIAL PRESSURE PILOT

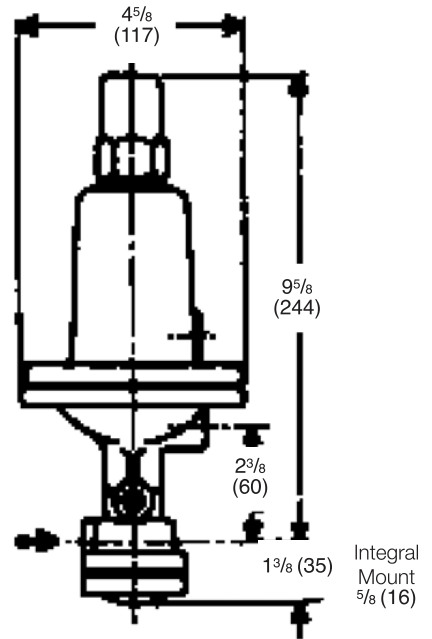

TYPE N PILOT
8 LBS.
(3.6 KG)

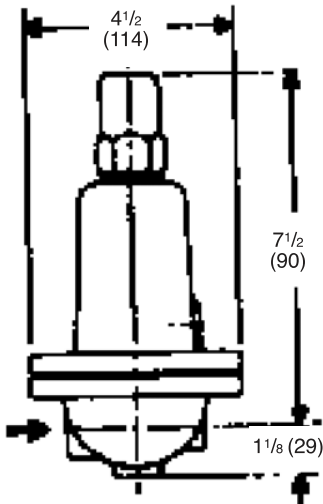

TYPE N20 PILOT
8 LBS.
(3.6 KG)

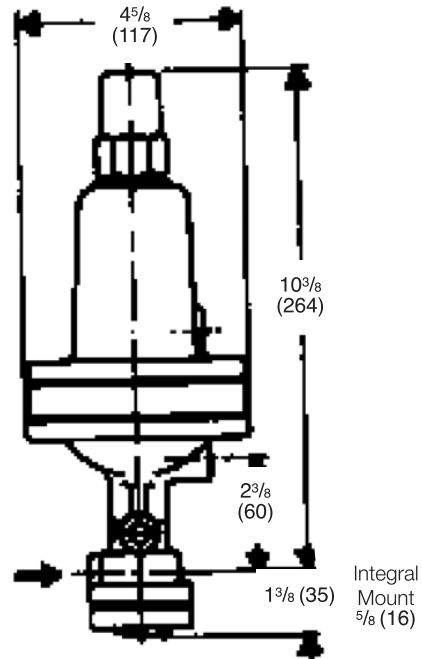

TYPE N33 PILOT
11 LBS.
(5 KG)