



TYPE T52 TEMPERATURE PILOT

APPLICATION DATA

- Control Flow of Cooling Liquid
- Blending

RATINGS (Maximum Inlet Conditions)

Construction	Pressure PSIG (bar)	Temperature °F (°C)
Cast Iron	250 (17.2)	@ 450 (232)
Cast Steel	600 (41.4)	@ 750 (400)

TEMPERATURE RANGES (°F)

20-120	150-300	300-400
50-150	170-270	330-430
70-170	250-350	400-500
120-220	290-390	

Canadian Registration # OC 0591.9C

SIZING INFO
PAGE 114

TYPE T52 TEMPERATURE PILOT

CONTROLS 20 to 500°F

- Spring Operated
- Self Contained
- Normally Closed, Indirect Operation (Cooling)
- Packless Construction
- Fluid, Gas and Vapor Applications
- Strainer Screen Built-in
- Easy in-line Maintenance

OPTIONS

- Stainless Steel Flexible Tubing
- Stainless Steel Capillary Tubing
- Tubing longer than 10'
- Thermostat Well
- Dial Thermometer
- Integral Mount
- Thermostat other than #700 (see Bulb Options, pg 82)

THERMOSTATS

700	706	731
701	708	732
702	711	740
703	712	800
704	713	801

TYPICAL CONFIGURATIONS

COOLING	C34T52
COOLING & PRESSURE	C34T52D
COOLING	E6T52
COOLING & PRESSURE.....	E6T52D
COOLING	ET52
COOLING & PRESSURE	ET52D
COOLING	E2T52
COOLING & PRESSURE.....	E2T52D
COOLING	E5T52
COOLING & PRESSURE.....	E5T52D

TYPE T52 TEMPERATURE PILOT

SPECIFICATION

Pilot valve is for cooling applications (reverse acting). Pilot valve shall be separate from the main valve and connected to it by unions. Pilot seats shall be protected by built-in strainer screens. Pilot shall be interchangeable on all sizes of main valves. Thermal elements shall provide a 100°F (38°C) range of temperature adjustment and shall withstand 100°F overheating without damage. Handwheel adjustment for temperature shall be standard. Unless otherwise scheduled, thermal elements shall be equipped with 10 feet of brass flexible tubing. Number 700 bronze bulb, Number 728 bronze well shall be supplied for storage tank applications. Steel wells shall be supplied for fuel oil service.

MATERIALS OF CONSTRUCTION

Body, Cast Iron	ASTM A126 C53
Body, Steel	ASTM A108-79
Stem	303 St. Stl ASTM 582 Cond. A
Disc	440 St. Stl. ASTM 276-75 Cond. A
Seat	420 St. Stl ASTM 276 Cond. A
Gasket	Graphite
Diaphragm	PH Bronze
Spring	Inconel

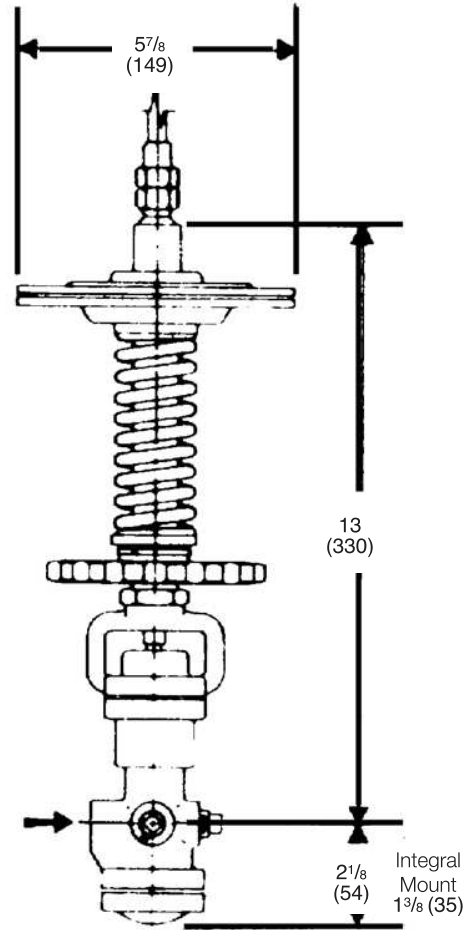
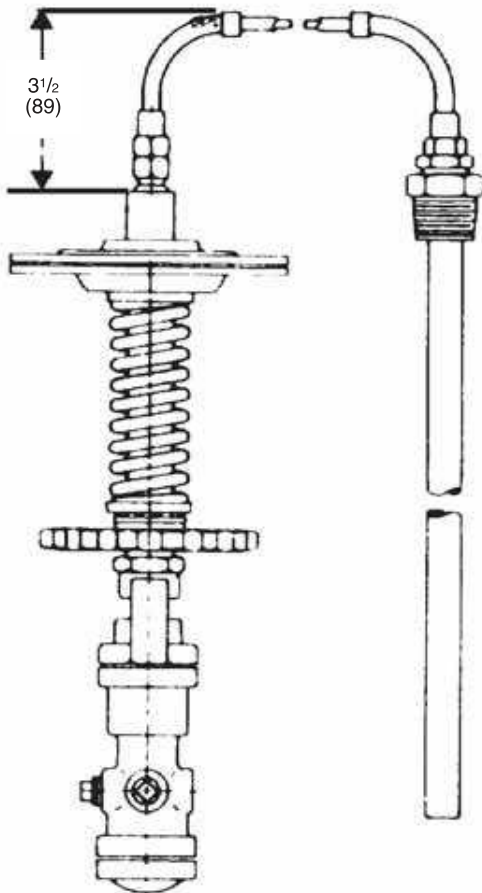

**TYPE T52 PILOT
14 LBS. (6.4 KG)**

TYPE T52
TEMPERATURE PILOT