



TITAN FLOW CONTROL, INC.

"Y" (WYE) STRAINER ♦ BUTT WELD ENDS

ANSI CLASS 900 ♦ CARBON AND STAINLESS STEEL

MODELS: YS 67-CS
(CARBON STEEL)

YS 67-SS
(STAINLESS STEEL)

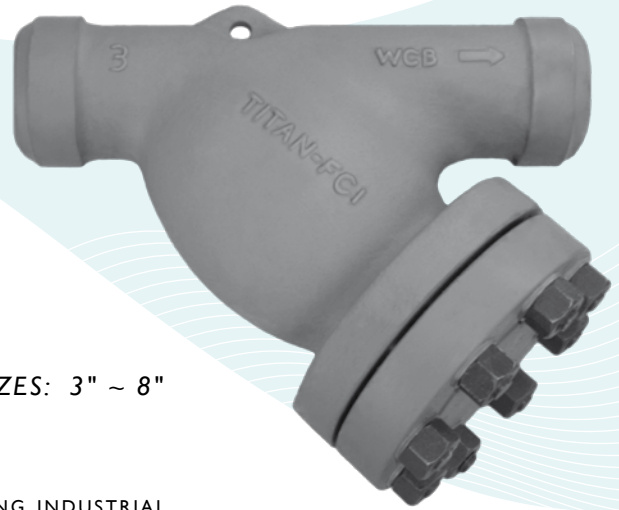

SIZES: 3" ~ 8"

FEATURES

- ◆ **RUGGED - HIGH QUALITY DESIGN**
TITAN'S YS67 IS IDEAL FOR PETROCHEMICAL AND OTHER DEMANDING INDUSTRIAL APPLICATIONS THAT HAVE HIGHER PRESSURE AND TEMPERATURE REQUIREMENTS. THIS UNIT EMPLOYS HEAVY GAUGE, REINFORCED SCREENS TO PREVENT DAMAGE TO THE STRAINING ELEMENT. BOLT HOLES ARE ALSO BACK OR SPOT FACED.
- ◆ **LARGE STRAINING CAPACITY**
WITH ITS LARGE BODY AND SIZABLE STRAINING ELEMENT, THE YS67 PROVIDES EXCELLENT OPEN AREA RATIOS THAT ARE TYPICALLY TWO-AND-A-HALF TIMES LARGER THAN THE CORRESPONDING PIPELINE.
- ◆ **PRECISION MACHINED SEATS**
PRECISION MACHINED SCREEN SEATS IN BOTH THE BODY AND CAP HELP TO ENSURE ACCURATE POSITIONING OF THE SCREEN DURING REASSEMBLY AFTER CLEANING. ALSO, THE MACHINED BODY SEATS ENABLE FINER FILTRATION BY PREVENTING DEBRIS BYPASS.
- ◆ **ENCAPSULATED "CG" STYLE GASKET**
THE "CG" STYLE COVER GASKET PROVIDES ADDITIONAL RADIAL STRENGTH TO PREVENT GASKET BLOWOUT. IT ALSO ACTS AS A COMPRESSION STOP.
- ◆ **SELF-CLEANING CAPABILITY**
WITH THE OPTIONAL SOCKET WELD BLOW-OFF CONNECTION, THIS UNIT CAN BE FITTED WITH A BLOW-DOWN VALVE WHICH FACILITATES CLEANING OF THE STRAINING ELEMENT. PLEASE CONTACT FACTORY FOR MORE INFORMATION.
- ◆ **EPOXY PAINTED**
CARBON UNITS ARE EPOXY PAINTED TO HELP RESIST RUST AND CORROSION. TITAN FCI ALSO OFFERS EPOXY COATING. PLEASE CONTACT FACTORY FOR MORE INFORMATION.

TECHNICAL

PRESSURE/TEMPERATURE RATING CS - ASTM A216 GR. WCB - CLASS 900

WOG (Non-shock): 2220 PSI @ 100 °F
Saturated Steam: 900 PSI @ 534 °F
Maximum Liquid: 1225 PSI @ 800 °F

PRESSURE/TEMPERATURE RATING SS - ASTM A351 GR. CF8M - CLASS 900

WOG (Non-shock): 2160 PSI @ 100 °F
Saturated Steam: 900 PSI @ 534 °F
Maximum Liquid: 1050 PSI @ 1000 °F

- The above listed temperatures are theoretical and may vary during actual operating conditions.
- Carbon Steel not recommended for prolonged use above 800 °F.
- Stainless Steel not recommended for prolonged use above 1000 °F.

APPLICATIONS

CARBON STEEL PROPERTIES: CARBON STEEL PERFORMS EXCEPTIONALLY WELL IN HIGH TEMPERATURES, UP TO 800°F IN CONTINUOUS SERVICE. IT PROVIDES HIGH RESISTANCE TO SHOCK, VIBRATION, PIPING STRAINS, AND FIRE AND FREEZING HAZARDS. CARBON STEEL STRAINERS ARE OFTEN USED IN THE OIL AND PETROCHEMICAL INDUSTRIES.

STAINLESS STEEL PROPERTIES: STAINLESS STEEL IS COMMONLY SPECIFIED FOR HIGH TEMPERATURE SERVICE, UP TO 1000°F IN CONTINUOUS SERVICE. STAINLESS STEEL STRAINERS ARE COMMONLY FOUND IN THE CHEMICAL, FOOD, AND PHARMACEUTICAL INDUSTRIES.

The above data represents common market and service applications. No representation or guarantee, expressed or implied, is given due to the numerous variations of concentrations, temperatures and flow conditions that may occur during actual service.

TITAN FLOW CONTROL, INC.

YOUR PIPELINE TO THE FUTURE!

Tel: 910-735-0000 ♦ Fax: 910-738-3848 ♦ titan@titanfci.com ♦ www.titanfci.com
290 Corporate Drive ♦ PO Box 7408 ♦ Lumberton, NC 28358



TITAN FLOW CONTROL, Inc.
 290 Corporate Drive
 Lumberton, NC 28358
 Tel: 910.735.0000
 E-mail: titan@titanfci.com
 Web: www.titanfci.com
 Fax: 910.738.3848

WYE STRAINER
YS 67-CS - (Carbon Steel)
YS 67-SS - (Stainless Steel)
Butt Weld Ends • Carbon & Stainless Steel

ANSI Class 900

BILL OF MATERIALS ⁽¹⁾

No.	PART	YS 67-CS ⁽²⁾	YS 67-SS
1	Body	Carbon Steel A216 Gr. WCB	Stainless Steel A351 Gr. CF8M Type 316
2	Cover	Carbon Steel A216 Gr. WCB	Stainless Steel A351 Gr. CF8M Type 316
3	Straining Element ⁽³⁾	Stainless Steel	Stainless Steel
4	Gasket ⁽³⁾	Stainless Steel CG Style	Stainless Steel CG Style
5	Studs	Alloy Steel	Alloy Steel
6	Nuts	Alloy Steel	Alloy Steel

1. Bill of Materials represents standard materials. Equivalent or better materials may be substituted at the manufacturer's discretion.
2. Carbon Steel bodies are epoxy painted.
3. Denotes recommended spare parts.

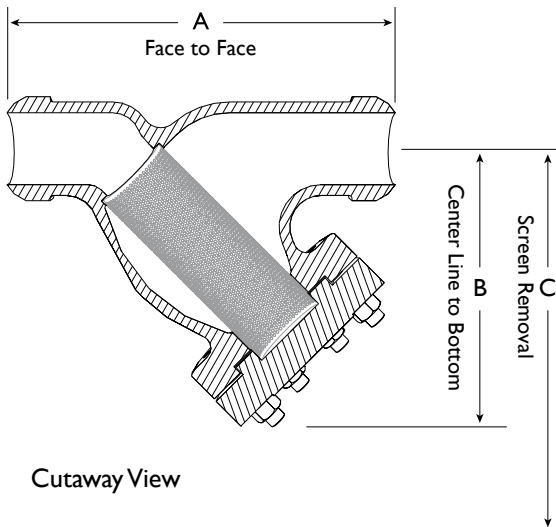
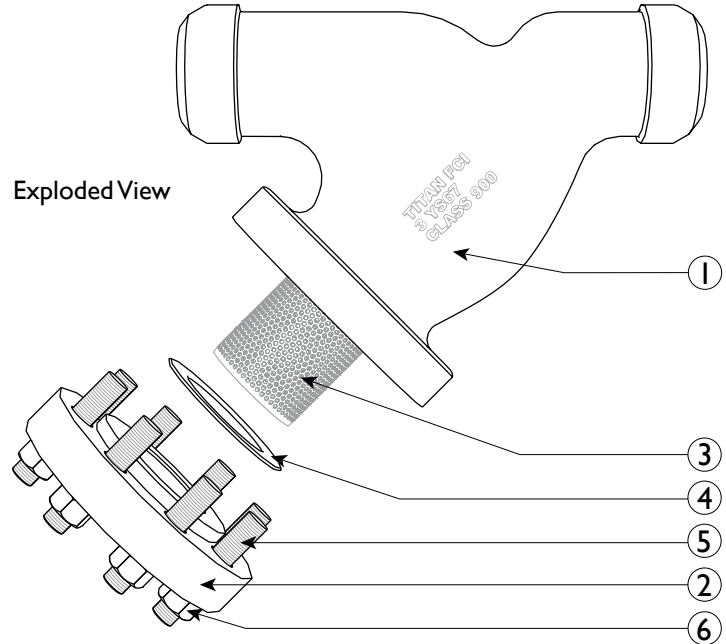

Cutaway View

ANSI Class 900 Butt Welded ends have a schedule of 160.

Illustrations are representative of sizes 3" through 8".
 Please ask for certified drawings when required.

REFERENCED STANDARDS & CODES

CODE	DESCRIPTION
ASME/ANSI B16.25	Butt Welding Ends
ASME/ANSI B16.34	Flanged, Threaded, and Welding End

PRESSURE - TEMPERATURE RATING

Body Material	A216 Gr. WCB	A351 Gr. CF8M
WOG (Non-shock):	2220 PSI @ 100 °F	2160 PSI @ 100 °F
Saturated Steam:	900 PSI @ 534 °F	900 PSI @ 534 °F
Max Liquid:	1225 PSI @ 800 °F	1050 PSI @ 1000 °F

STANDARD SCREEN SELECTIONS

Size	Liquid	Open Area	Steam	Open Area
3" ~ 4"	1/16 (.0625)	41%	1/32 (.033)	28%
8"	1/8 (.125)	40%	3/64 (.045)	36%

DIMENSIONS AND PERFORMANCE DATA ⁽¹⁾

SIZE	in	3	4	6	8
	mm	80	100	150	200
A DIMENSION FACE TO FACE	in	15.50	18.13	21.50	25.0
	mm	394	461	546	635
B DIMENSION CENTER LINE TO BOTTOM	in	11.46	14.45	19.0	20.0
	mm	291	367	483	508
C DIMENSION SCREEN REMOVAL	in	17.50	18.50	26.0	28.5
	mm	445	470	660	724
APPROXIMATE ASSEMBLED WEIGHT	lb	80.0	156.0	C/F	468.0
	kg	36.2	70.8	C/F	212.3
Flow Coefficient	C _v	140	180	450	650

1. Dimensions, weights, and flow coefficients are for reference only. When required, request certified drawings.

PRESSURE - TEMPERATURE RATINGS

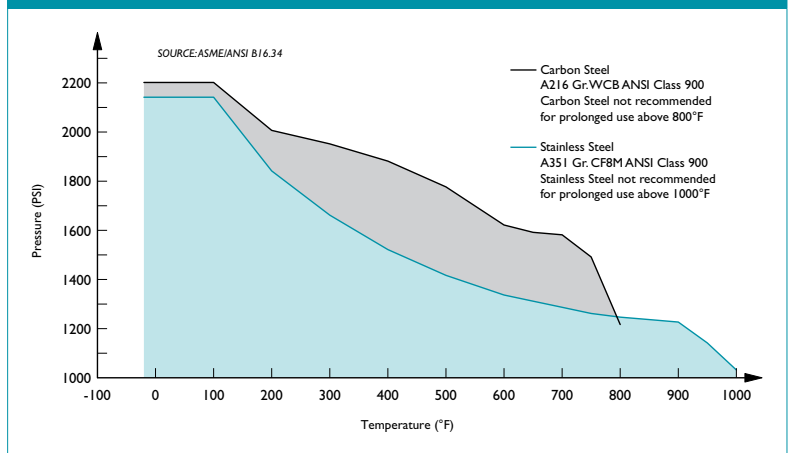

Additional Design & Technical Notes:

- Butt weld ends are X-rayed to ensure high quality.
- An optional socket weld blow-off is available. Please contact factory.
- NPT blow-offs are not recommended for ANSI Class 900 strainers.
- Bodies are also available in high temperature steel A217 Gr. WC6 and WC9. Please contact factory for price and delivery.

Titan FCI makes every effort to ensure the information presented on our literature accurately reflects exact product specifications. However, as product changes occur, there may be short-term differences between actual product specifications and the information contained within our literature. Titan FCI reserves the right to make design and specification changes to improve our products without prior notification. When required, request certified drawings.