

# Operating Instructions

## Intrinsically Safe Isolation Relay for Switches

**Model: REL-6003**



## 1. Contents

---

1. Contents.....	2
2. Note .....	3
3. Instrument Inspection.....	3
4. Regulation Use .....	3
5. Operating Principle .....	4
6. Mechanical Connection.....	4
6.1 Front View .....	4
6.2 Installation of devices outside of hazardous areas .....	5
7. Mechanical Connection.....	6
8. Electrical Connection .....	7
Switch S1 (relay output mode):.....	7
Switch S2:.....	7
8.1 Electrical Standards.....	8
9. Maintenance .....	8
10. Order code .....	9
11. Technical Information.....	9
12. Dimensions .....	11

**Manufactured and sold by:**

Kobold Instruments Inc.  
1801 Parkway View Drive  
Pittsburgh, PA 15205  
Tel.: 412-788-2830  
Fax: 412-788-4890  
E-Mail: [info@koboldusa.com](mailto:info@koboldusa.com)  
Internet: [www.koboldusa.com](http://www.koboldusa.com)

## **2. Note**

---

Please read these operating instructions before unpacking and placing the unit in operation and follow the instructions precisely as described herein.

The devices are only to be used, maintained and serviced by persons familiar with these operating instructions and in accordance with local regulations applying to Health & Safety and prevention of accidents.

## **3. Instrument Inspection**

---

Instruments are inspected before shipping and sent out in perfect condition. Should damage to a device be visible, we recommend a thorough inspection of the delivery packaging. In case of damage, please inform your parcel service/forwarding agent immediately, since they are responsible for damages during transit.

### **Scope of delivery:**

The standard delivery includes:

- Intrinsically Safe Isolation Relay model: REL-6xxx
- Operating Instructions

## **4. Regulation Use**

---

Any use of the Intrinsically Safe Isolation Relay, model: REL-, which exceeds the manufacturer's specifications, will invalidate the warranty. Therefore, any resulting damage is not the responsibility of the manufacturer. The user assumes any and all risk for such usage.

The REL- series Isolation Relay provides an intrinsically safe control circuit allowing simple apparatus (dry contacts) or NAMUR type switches to operate control devices within hazardous areas.

The data sheets of the individual devices contain the specific electrical data limits for the specific component and must be considered as an essential component of the instruction manual.

## 5. Operating Principle

---

The REL-series Intrinsically Safe Isolation Relay transmits digital signals from hazardous areas. Sensors according to DIN 19 234 (NAMUR) or mechanical (dry) contacts may be used as signal transmitters. If desired, the control circuit may be monitored for line breakage (LB) and/or short circuit (SC) conditions.

The input is galvanically isolated from the output circuit according to DIN EN 50178. The device is fitted with detachable terminals that greatly simplify the wiring installation.

## 6. Mechanical Connection

---



**Commissioning and installation must only be performed by competent professionals suitably trained for this purpose.**

---

### 6.1 Front View

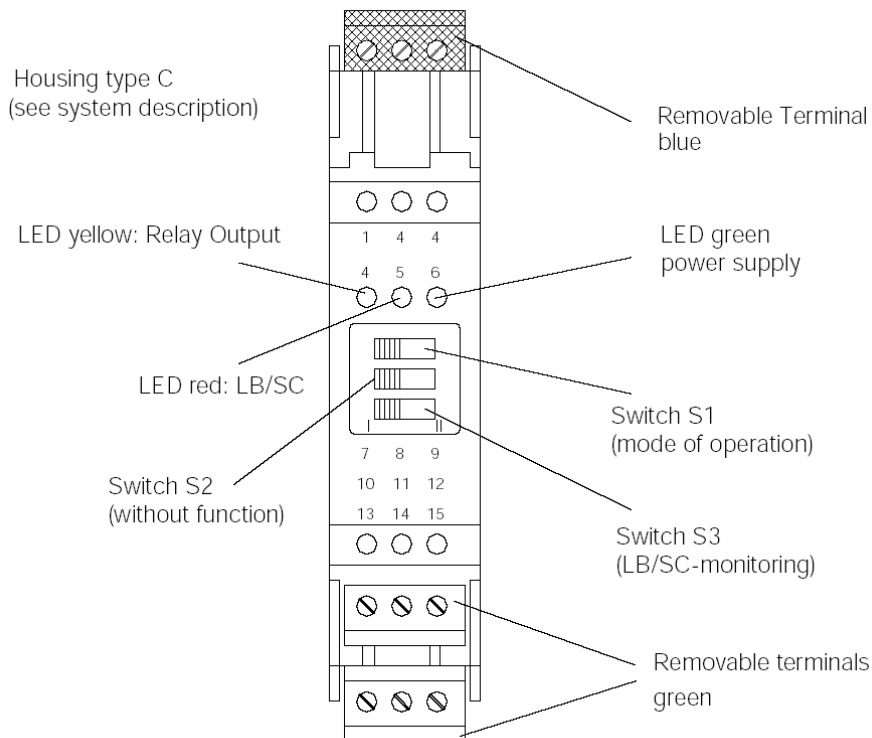

## **6.2 Installation of devices outside of hazardous areas**

- The devices are constructed to satisfy the IP20 protection classification and must be protected accordingly from adverse environmental conditions such as water spray or dirt.
- The devices must be installed outside the hazardous area!
- Depending on the ignition protection class, intrinsically safe circuits of devices (light blue marking on the devices) may be placed in hazardous areas. In this case, particular care must be taken to ensure secure separation from all non-intrinsically safe circuits. The installation of the intrinsically safe circuits must be conducted in accordance with the relevant section of the National Electrical Code.
- The respective peak values of the field device and the associated device with regard to explosion protection should be considered when connecting intrinsically safe field devices with the intrinsically safe circuits of the devices (definition of intrinsic safety). The provisions of EN 60079-14/IEC 60079-14 must be observed in this regard.
- When intrinsically safe circuits are used in areas made hazardous by dust (Ex-Zone "D") only appropriately certified field devices must be used.
- The EC Certificates of Conformity or the EC Declarations of Conformity must be observed. It is especially important to observe the "Special Conditions" where these are contained in the certificates.

## 7. Mechanical Connection

---

The devices can be easily mounted in two ways:

1. Panel / Wall mounting (K-system only)
2. Mounting on a 35 mm standard DIN rail to DIN EN 50 022

Panel mounting is only recommended if a very small number of isolating modules are involved.

When mounting on the DIN rail, the units are simply snapped on. The expenditure on wiring for the power supply is significantly reduced by using "Power Rail".

### The devices, with removable terminals

The removable terminals simplify control cabinet construction and allow the units to be replaced while under power. The screw-in self-opening apparatus terminals have a high volume connection area for a wire cross-section of up to 2.5 mm<sup>2</sup>. Connectors are coded, making it impossible for them to be confused. With the KF-CP coding profile, separately available connectors with test sockets or cage spring release terminals can be easily coded.

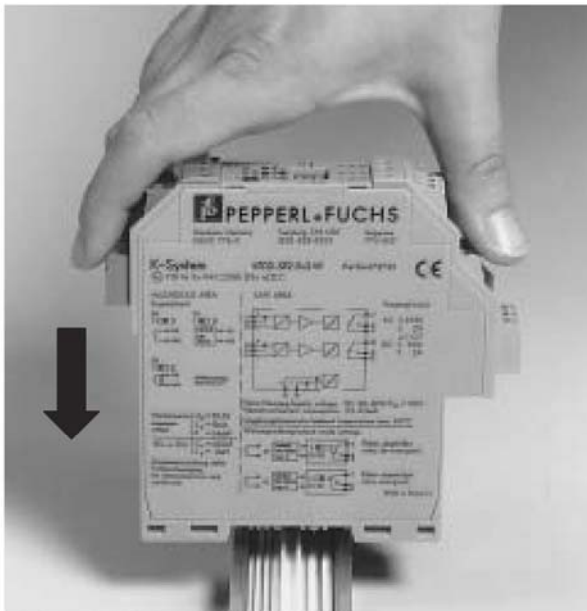

**CORRECT:** Unit snapped on vertically.



**INCORRECT:** Unit snapped on at an angle

## 8. Electrical Connection

### Switch S1 (relay output mode):

Position I: Relay de-energized with "open" input circuit

Position II: Relay energized with "open" input circuit

### Switch S2:

Not Connected / No function

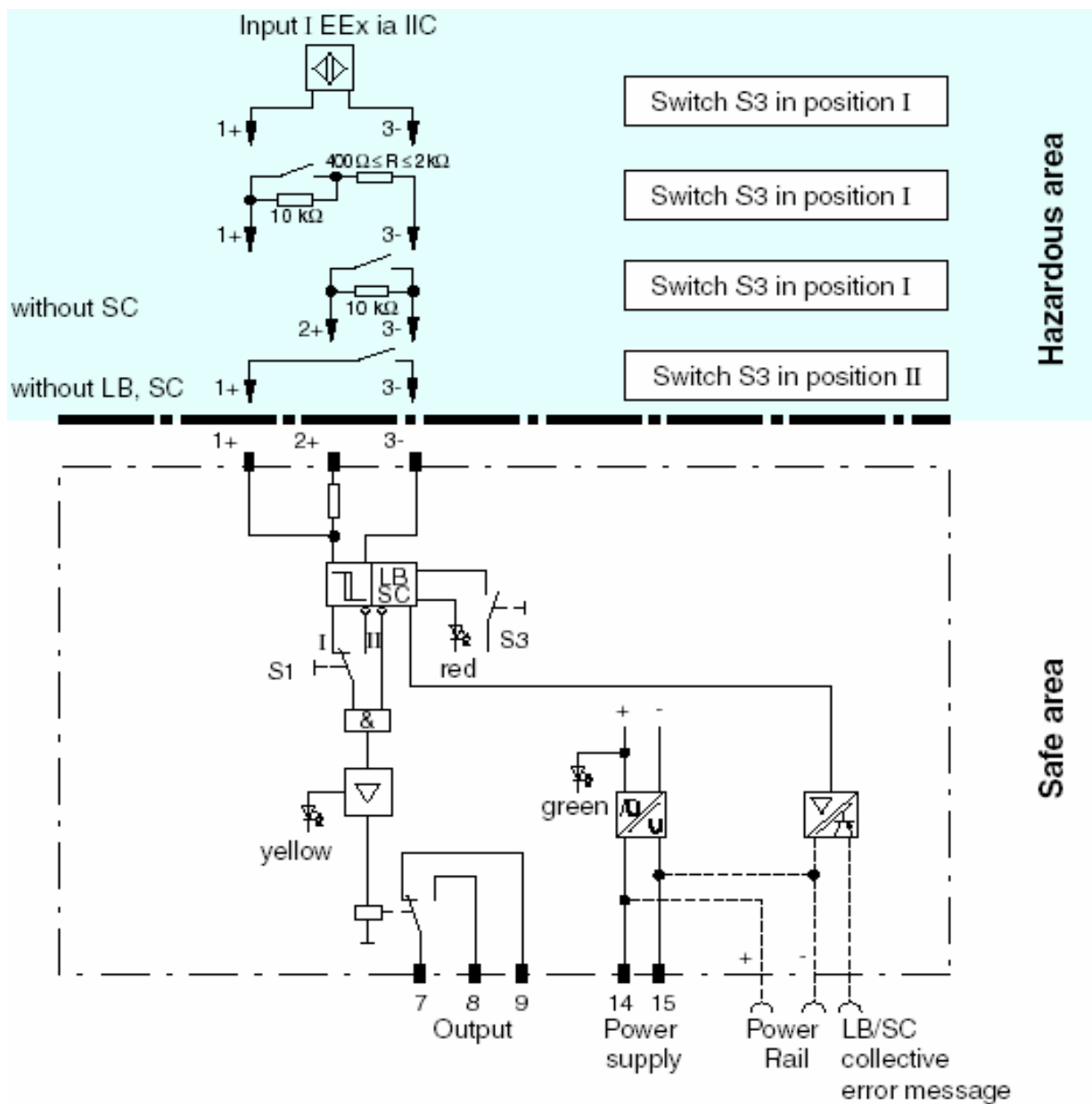

## 8.1 Electrical Standards

Separating components with and without Ex-protection, especially EEx ia IIC, international approval

EMV according NAMUR NE 21 and EN 50081-2, EN 61326,

LED according NAMUR NE 44, Software according NAMUR NE 53,

Start up-pulse compression

Supply voltage DC min. 20...30 V

DC: Power Rail, feeder clamp

Fault information by Power Rail

Software Operating surface according VDE/VDI 2187

Safety units according VDE 0660 T.209, AK according DIN 19250

### Binary inputs/outputs in accordance with NAMUR

The standards references for this interface have changed many times:

German standard (old): **DIN 19234**: Electrical distance sensors - DC interface for distance sensors and switch amplifiers; 1990-06

European standard (old): **EN 50227**: Low voltage switch gear and control gear - control devices and switching elements - proximity switches, DC interface for proximity sensors and switch amplifiers (NAMUR), 1996-10

German version (old): **DIN EN 50227**: Low voltage switchgear - control devices and switching elements - proximity switches, DC interface for proximity sensors and switch amplifiers (NAMUR), 1997, German nomenclature VDE 0660 Part 212

**Current designation: DIN EN 60947-5-6**: Low voltage switchgear - control devices and switching elements - proximity switches, DC interface for proximity sensors and switch amplifiers (NAMUR), 2000, German nomenclature. VDE 0660 Part 212

**Current IEC designation: IEC 60947-5-6**: Low voltage switchgear and control gear - Part 5-6: Control circuit devices and switching elements - DC interface for proximity sensors and switching amplifiers (NAMUR), 1999

## 9. Maintenance

---

The transfer characteristics of the devices remain stable, even over long periods of time, thus eliminating any need for adjustments. Therefore, maintenance is not required.

No changes may be made to devices which are operated in hazardous areas. Repairs to devices must only be carried out by specially trained and qualified personnel.



## 10. Order code

---

Example:  
REL-6003 (single channel)

## 11. Technical Information

---

### Supply Voltage

Terminals:	14, 15
Nominal supply voltage:	103.5-126 VAC, 45-65 Hz
Power:	1.3W max.
Current:	13 mA max.

### Input Signal

*Intrinsically safe according to NAMUR and DIN 19234*

Terminals:	1+, 2+, 3-
Floating voltage:	approximately 8 VDC
Short circuit current:	approximately 8 mA
Input pulse length:	≥ 20 ms
Input pulse period:	≥ 20 ms
Line monitoring:	Breakage ≤ 0.1 mA / Short-circuit > 6 mA

### Entity Parameters

Terminals:	1+, 2+, 3-		
FM control drawing no.	116-0035		
Voltage $V_{OC}$ :	12.9 V		
Current $I_{SC}$ :	19.8 mA		
Explosion group:	A & B	C & E	D, F & G
Max. External capacitance ( $C_a$ )	1.2 $\mu$ F	3.8 $\mu$ F	10.1 $\mu$ F
Max. External inductance ( $L_a$ )	84.8 mH	254.4 mH	678.4 mH

### Output

# REL-6

---

*Changeover (SPDT) contact, not intrinsically safe*

Terminals:	SPDT: 7 (common), 8 (n/o), 9 (n/c)
Contact load:	250 VAC/2 A/cos $\phi > 0.7$ 120 VAC/4A 40 VDC/2 A resistive load
Mechanical service life:	$10^7$ switching cycles
Switching delay:	approximately 20 ms
Switching frequency:	$\leq 10$ Hz
Case material:	Polycarbonate (Macrolon)
Dimensions:	118 x 20 x 115 mm (H x W x D)
Protection:	IP 20
Ambient temperature:	-20°C to +60°C (-4°F to +140°F)
Weight:	approximately 150 g (5.3 oz.)

## 12. Dimensions

