



MARSHALL ENGINEERED PRODUCTS CO.

FORM 1622B

PUMP SECTION

Centrifugal Pumps, Type RC12 - Close Coupled, End Suction

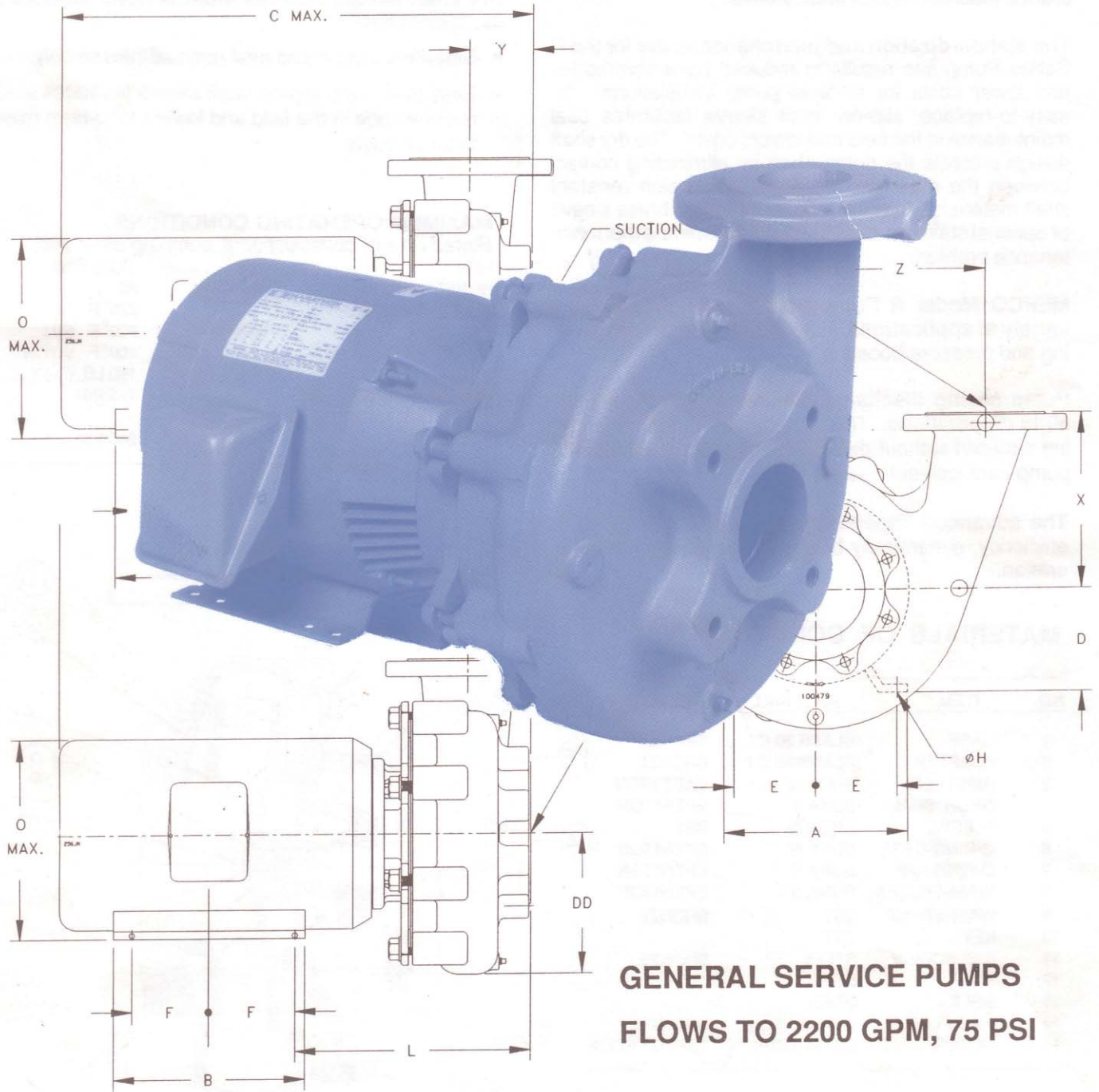

MEPCO 3056 Walker Ridge Drive, Suite C, Grand Rapids, MI 49544 616-246-1431

APPLICATIONS/FEATURES

The **MEPCO Model R Series Pumps** meet the latest standards for hydraulic performance and dimensional characteristics. The pump shall be close coupled to a NEMA standard JM motor. The pump incorporates a dry shaft design to prevent the fluid from contacting the shaft. The shaft shall be covered with a replaceable bronze (stainless steel) shaft sleeve.

The **standardization and interchangeability** for the R Series Pump line results in reduced parts inventories and lower costs for multiple pump installations. An easy-to-replace, slip-on shaft sleeve facilitates seal maintenance in the field and lowers costs. The dry shaft design protects the pump shaft by eliminating contact between the shaft and the fluid. Corrosion resistant shaft materials are not required. Standard brass sleeve or optional stainless steel sleeve will eliminate this maintenance problem.

MEPCO Model R Pumps are ideally suited for a variety of applications, including heating, air conditioning and pressure boosting.

Pump casing discharge can be located in any of eight (8) positions. The pump shall be capable of being serviced without disturbing the system piping with pump back pull-out design.

The **advanced impeller design** maximizes hydraulic efficiency, dynamically balanced for vibration free operation.

The **mechanical seal is constructed of Buna N** shaft seal rated for 225 degrees Fahrenheit and pressures up to 175 PSI ceramic seat and carbon seal face for long trouble free service. Alternative seals are available to suit temperatures and liquid.

Dry shaft design ensures shaft is never exposed to the system fluid.

- Simplifies sleeve and seal removal/reassembly.
- Easy-to-replace slip-on shaft sleeve facilitates seal maintenance in the field and lowers long-term maintenance costs.

MAXIMUM OPERATING CONDITIONS

Based on std. construction & pumping clear water

RPM -	1150, 1750
HORSEPOWER -	60
STD. SEAL TEMP. -	225°F
OPT. SEAL TEMP. -	300°F EPT
OPT. SEAL TEMP. -	400°F VITON
MODEL RC -	150 LB. FLANGES
MAX. WORKING PRESS. -	175 PSI
HYDROSTATIC TEST PRESSURE -	265 PSI

MATERIALS OF CONSTRUCTION

NO.	ITEM	MATERIAL	OPTION
1	CASE	CLASS 30 C.I.	BRONZE
2	ADAPTER	CLASS 30 C.I.	BRONZE
3	IMPELLER	BRONZE	CAST IRON
4	MECH SEAL	BUNA N	EPT/VITON
5	SLEEVE	BRONZE	SST
6	O RING-CASE	BUNA N	EPT/VITON
7	O RING-IMP	BUNA N	EPT/VITON
8	WASHER, SEAL	BUNA N	EPT/VITON
9	WASHER-IMP	SST	BRONZE
10	KEY	SST	
11	CAP SCREW	STEEL	BRONZE
12	BOLT	STEEL	
13	BOLT	STEEL	
14	PIPE PLUG	CLASS 30 C.I.	BRONZE
15	MOTOR	NEMA (ODP)	TEFC/XPROOF

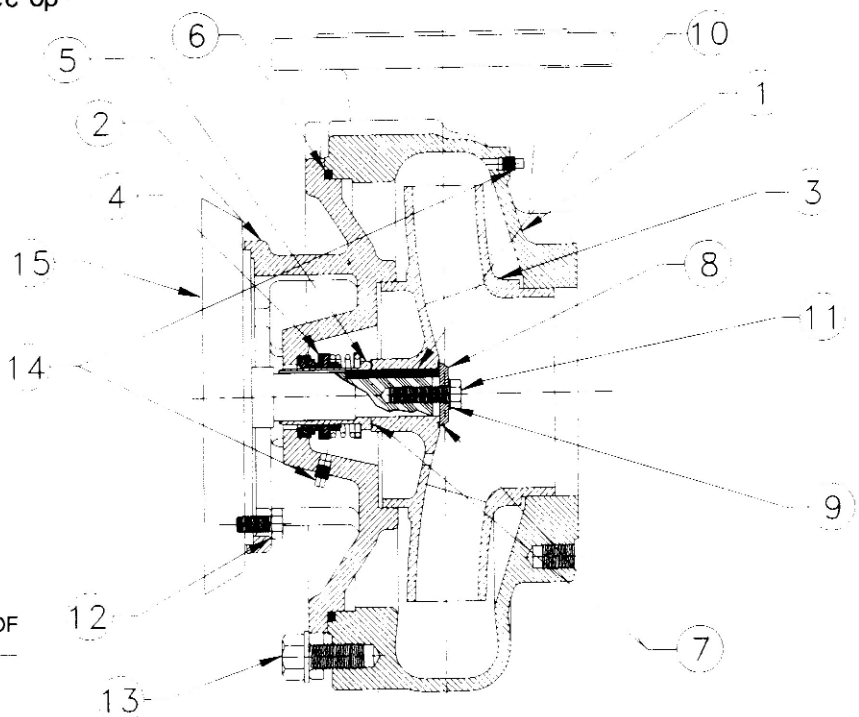

RAPID SELECTION CURVES

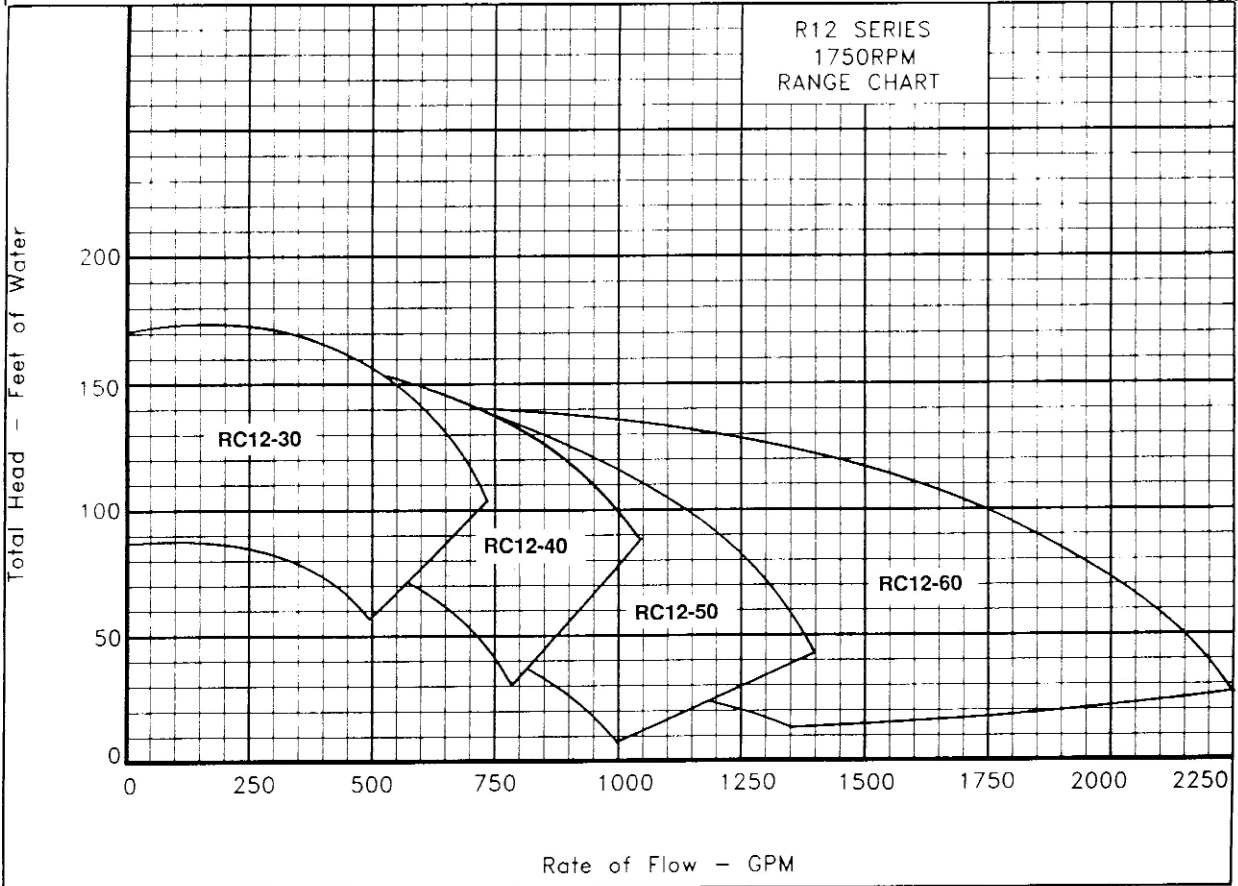
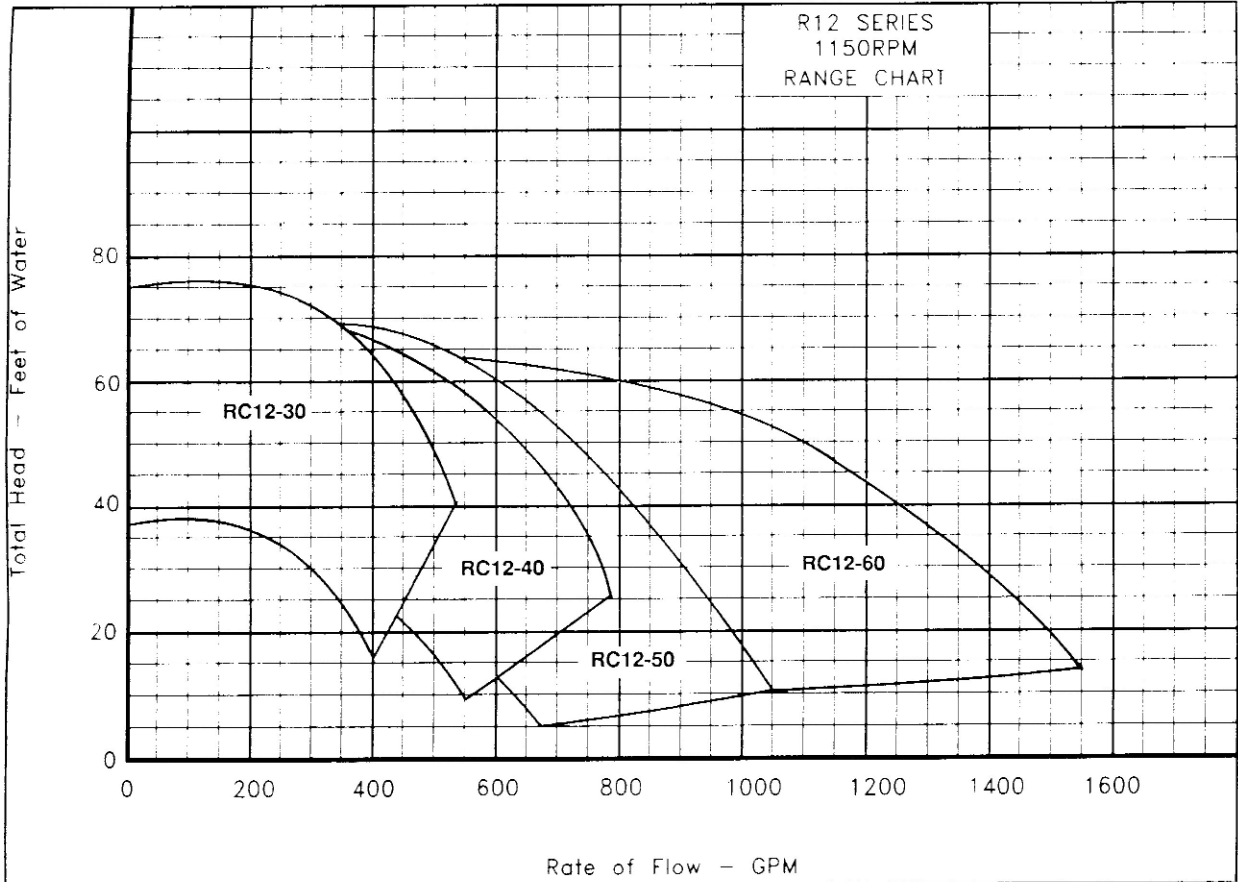

DIMENSIONS

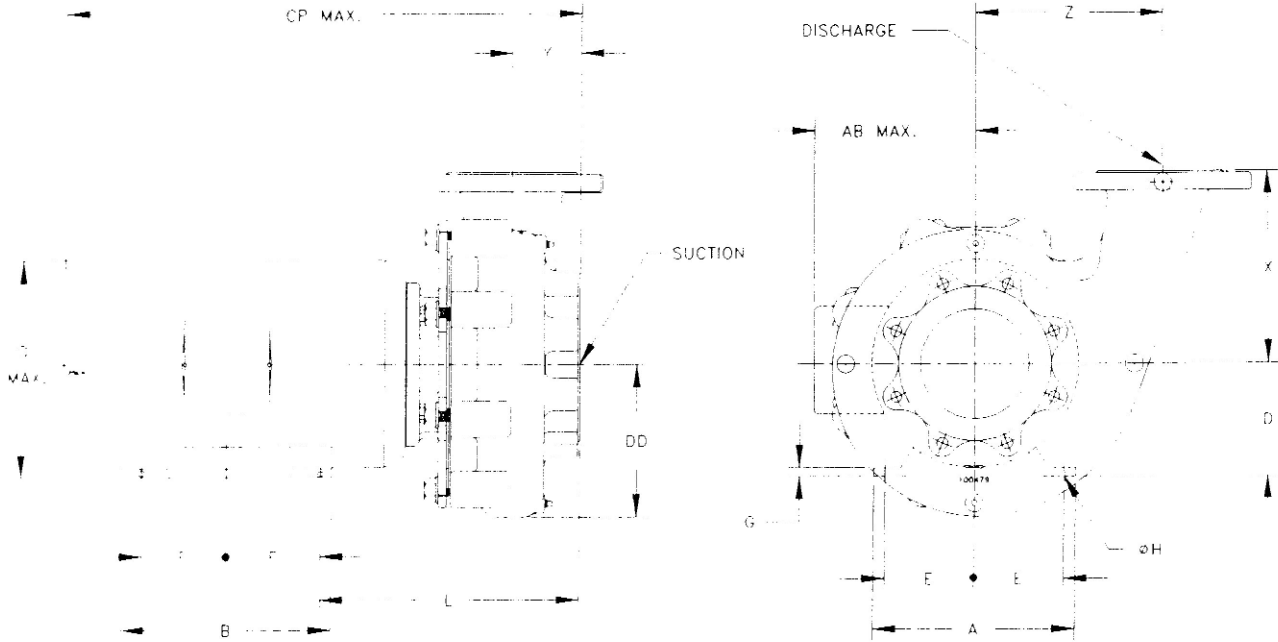

PUMP	MOTOR FRAME SIZE	DISC. NPT	SUCT. NPT	DIMENSIONS IN INCHES														
				A	AB	B	CP	D	DD	E	F	G	H	L	O	X	Y	Z
RC12 30	143JM	#3 FLANGE	#4 FLANGE	7	5 1/4	5 15/16	19 7/8	3 1/2	7 15/16	2 3/4	2	1/8	11/32	11 1/2	6 7/8	9 3/4	3 13/16	8 11/16
	20 5/8						2 1/2											
	145JM			9	5 7/8	6 1/2	20 7/8	4 1/2		3 3/4	2 1/4	3/16	13/32	12 1/4	8 7/16			
	22 3/8						2 3/4											
	182JM			10 1/2	7 3/8	8	23 3/8	5 1/4		4 1/4	2 3/4	1/4	13/32	13 1/16	10 1/16			
	25 3/8						3 1/2											
	184JM			11 1/4	8 15/16	9 1/2	28 3/8	6 1/4		5	4 1/8	1/2	17/32	14 1/16	12			
	28 3/4						5											
	213JM			12 1/4	12 1/4	12 1/4	29 1/4	7		5 1/2	4 3/4	1/2	17/32	14 1/16	13 5/8			
	30 1/4						5 1/2											
215JM	13 3/16	13 3/16	12	31 3/4	8	6 1/4	5 1/4	3/4	21/32	14 9/16	15 9/16							
32 3/4				6														
254JM	11 1/4	8 15/16	9 1/2	28 7/16	6 1/4	5	4 1/8	1/2	17/32	14 1/16	12							
28 3/4				5														
256JM	12 1/4	12 1/4	10 3/4	29 1/4	7	5 1/2	4 3/4	1/2	17/32	14 1/16	13 5/8							
30 1/4				5 1/2														
284JM	13 3/16	13 3/16	12	31 3/4	8	6 1/4	5 1/4	3/4	21/32	14 9/16	15 9/16							
32 3/4				6														
286JM	11 1/4	8 15/16	9 1/2	28 3/4	6 1/4	5	4 1/8	1/2	17/32	14 1/16	12							
28 3/4				5														
324JM	12 1/4	12 1/4	10 3/4	29 1/4	7	5 1/2	4 3/4	1/2	17/32	14 1/16	13 5/8							
30 1/4				5 1/2														
326JM	13 3/16	13 3/16	12	31 3/4	8	6 1/4	5 1/4	3/4	21/32	14 9/16	15 9/16							
32 3/4				6														
RC12 40	143JM	#4 FLANGE	#5 FLANGE	7	5 1/4	5 15/16	19 15/16	3 1/2	8 1/2	2 3/4	2	1/8	11/32	11 1/2	10	3 11/16	9 1/2	
	20 11/16						2 1/2											
	145JM			9	5 7/8	6 1/2	20 7/8	4 1/2		3 3/4	2 1/4	3/16	13/32	12 1/4				8 7/16
	22 3/8						2 3/4											
	182JM			10 1/2	7 3/8	8	23 7/16	5 1/4		4 1/4	2 3/4	1/4	13/32	13 1/8				10 1/16
	25 7/16						3 1/2											
	184JM			11 1/4	8 15/16	9 1/2	28 7/16	6 1/4		5	4 1/8	1/2	17/32	14 1/16				12
	28 3/4						5											
	213JM			12 1/4	12 1/4	10 3/4	29 1/4	7		5 1/2	4 3/4	1/2	17/32	14 1/16				13 5/8
	30 1/4						5 1/2											
215JM	13 3/16	13 3/16	12	31 3/4	8	6 1/4	5 1/4	3/4	21/32	14 9/16	15 9/16							
32 3/4				6														
254JM	11 1/4	8 15/16	9 1/2	28 7/16	6 1/4	5	4 1/8	1/2	17/32	14 1/16	12							
28 3/4				5														
256JM	12 1/4	12 1/4	10 3/4	29 1/4	7	5 1/2	4 3/4	1/2	17/32	14 1/16	13 5/8							
30 1/4				5 1/2														
284JM	13 3/16	13 3/16	12	31 3/4	8	6 1/4	5 1/4	3/4	21/32	14 9/16	15 9/16							
32 3/4				6														
RC12 50	143JM	#5 FLANGE	#6 FLANGE	7	5 1/4	5 15/16	20 1/8	3 1/2	8 17/32	2 3/4	2	1/8	11/32	11 11/16	10 1/2	3 7/8	10 7/16	
	20 7/8						2 1/2											
	145JM			9	5 7/8	6 1/2	21 1/16	4 1/2		3 3/4	2 1/4	3/16	13/32	12 7/16				8 7/16
	22 9/16						2 3/4											
	182JM			10 1/2	7 3/8	8	23 9/16	5 1/4		4 1/4	2 3/4	1/4	13/32	13 5/16				10 1/16
	25 9/16						3 1/2											
	184JM			11 1/4	8 15/16	9 1/2	28 9/16	6 1/4		5	4 1/8	1/2	17/32	14 1/4				12
	28 15/16						5											
	213JM			12 1/4	12 1/4	10 3/4	29 7/16	7		5 1/2	4 3/4	1/2	17/32	14 1/4				13 5/8
	30 7/16						5 1/2											
215JM	13 3/16	13 3/16	12	31 15/16	8	6 1/4	5 1/4	3/4	21/32	14 3/4	15 9/16							
32 15/16				6														
254JM	11 1/4	8 15/16	9 1/2	28 15/16	6 1/4	5	4 1/8	1/2	17/32	14 1/4	12							
28 15/16				5														
256JM	12 1/4	12 1/4	10 3/4	29 7/16	7	5 1/2	4 3/4	1/2	17/32	14 1/4	13 5/8							
30 7/16				5 1/2														
284JM	13 3/16	13 3/16	12	31 15/16	8	6 1/4	5 1/4	3/4	21/32	14 3/4	15 9/16							
32 15/16				6														
RC12 60	143JM	#6 FLANGE	#8 FLANGE	7	5 1/4	5 15/16	24 5/8	3 1/2	9 11/16	2 3/4	2	1/8	11/32	12	11 1/2	3 3/4	11 11/16	
	25 3/8						2 1/2											
	145JM			9	5 7/8	6 1/2	25 5/8	4 1/2		3 3/4	2 1/4	3/16	13/32	12 3/4				8 7/16
	27 1/16						2 3/4											
	182JM			10 1/2	7 3/8	8	28 1/8	5 1/4		4 1/4	2 3/4	1/4	13/32	13 5/8				10 1/16
	30 1/8						3 1/2											
	184JM			11 1/4	8 15/16	9 1/2	34 1/8	6 1/4		5	4 1/8	1/2	17/32	14 9/16				12
	34 1/2						5											
	213JM			12 1/4	12 1/4	10 3/4	35	7		5 1/2	4 3/4	1/2	17/32	14 9/16				13 5/8
	36						5 1/2											
215JM	13 3/16	13 3/16	12	37 1/2	8	6 1/4	5 1/4	3/4	21/32	15 1/16	15 9/16							
38 1/2				6														

SELECTION CURVES

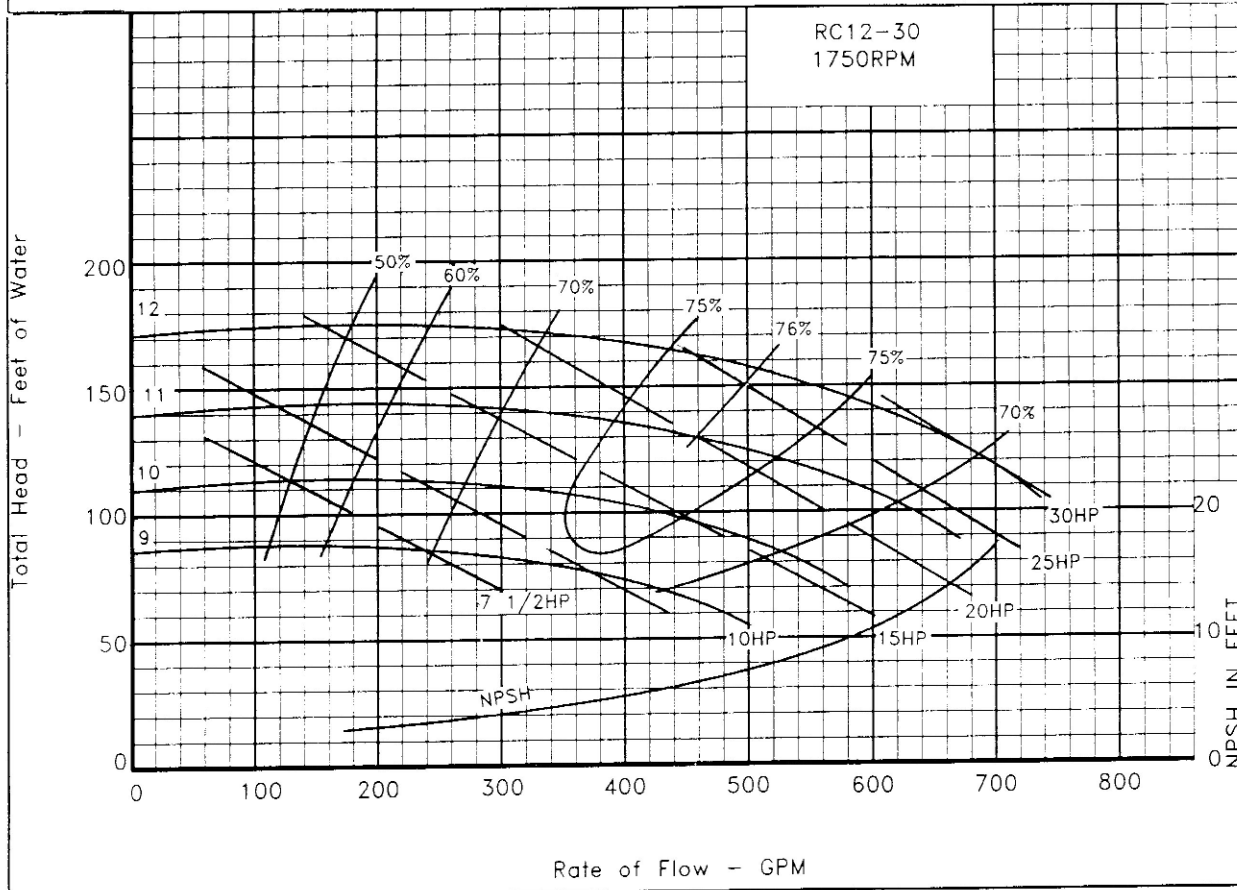
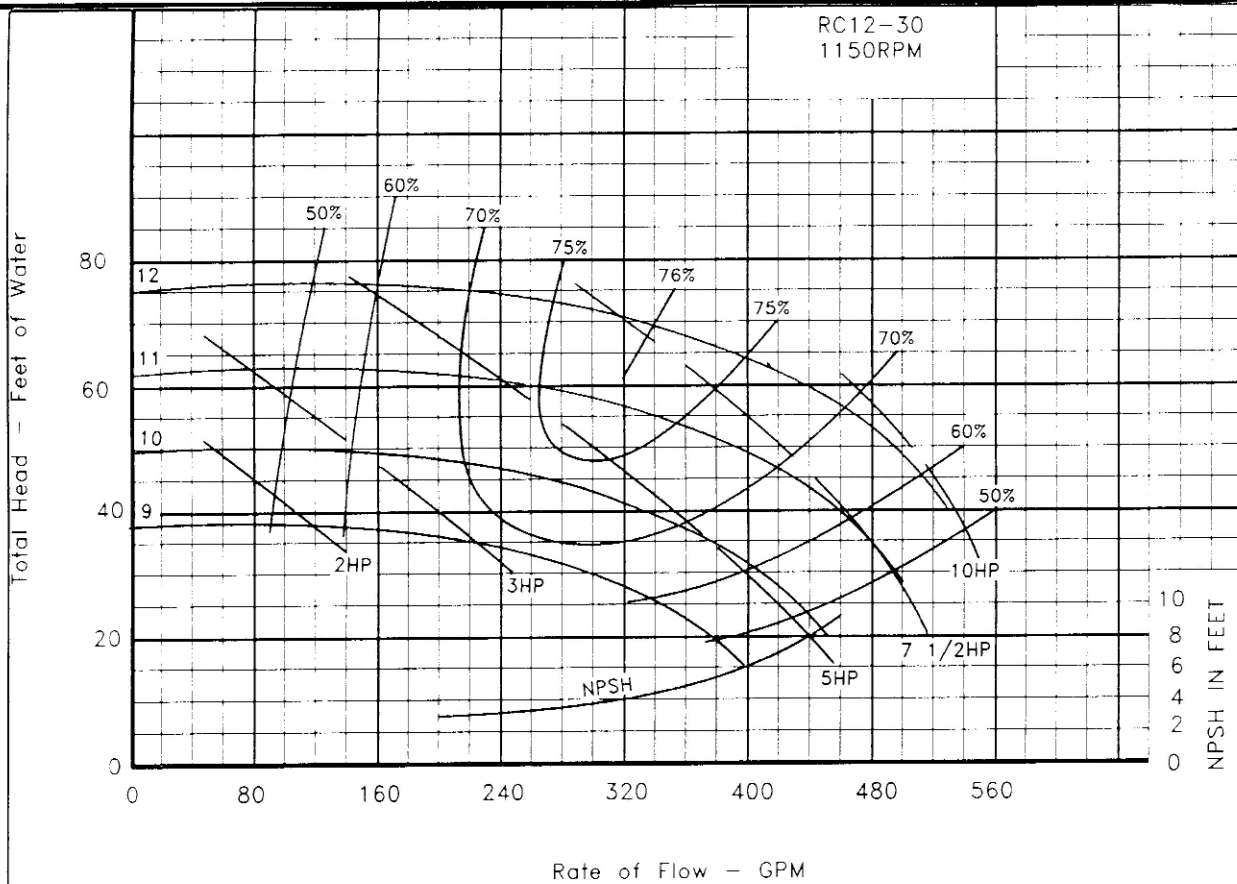

SELECTION CURVES

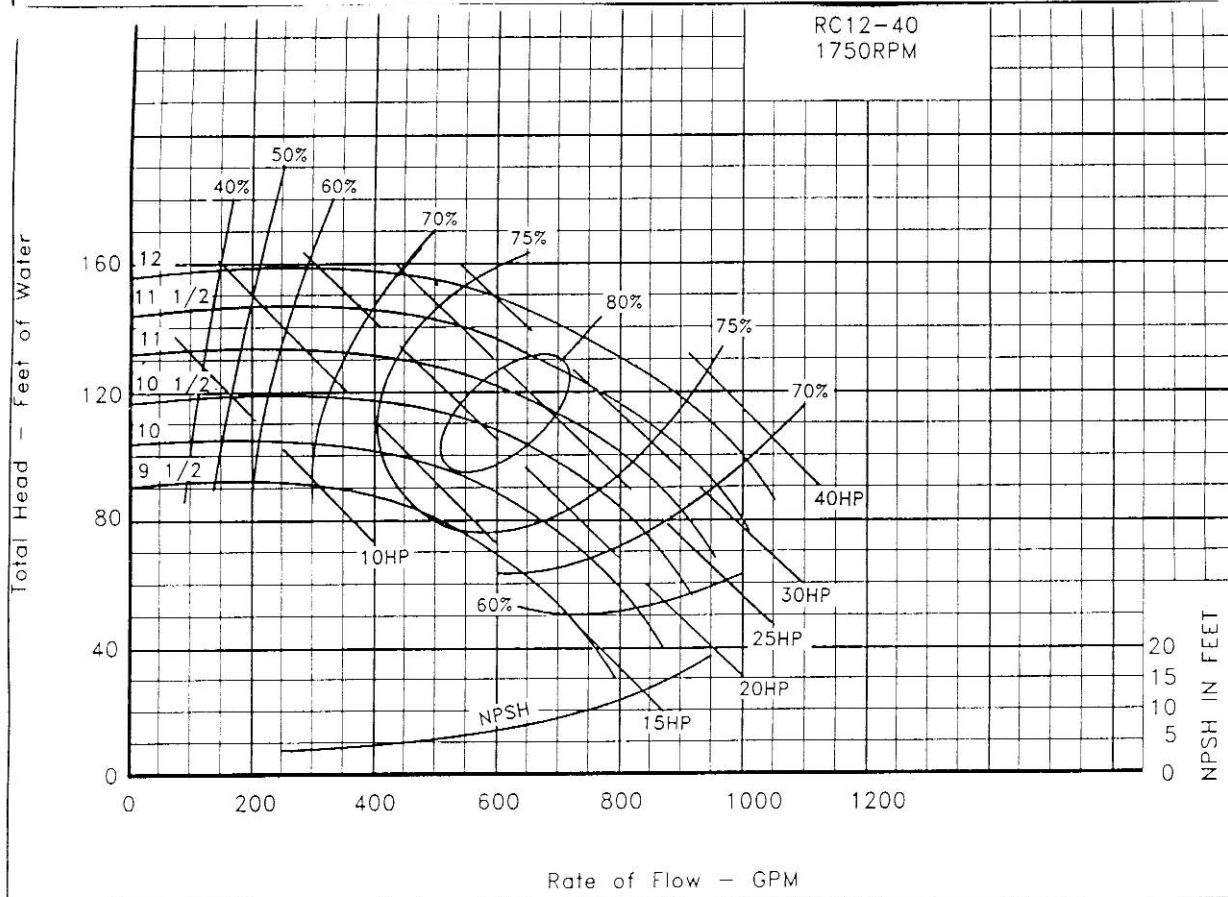
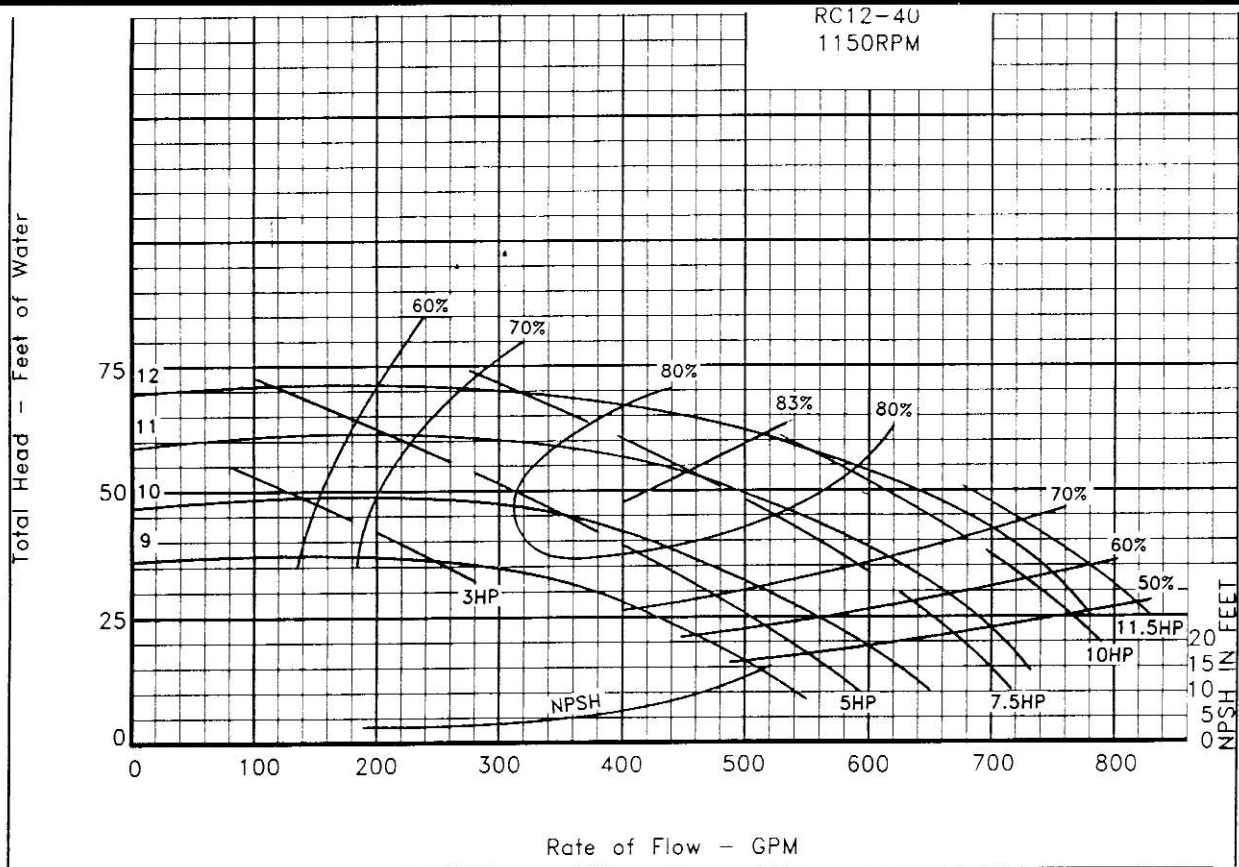

SELECTION CURVES

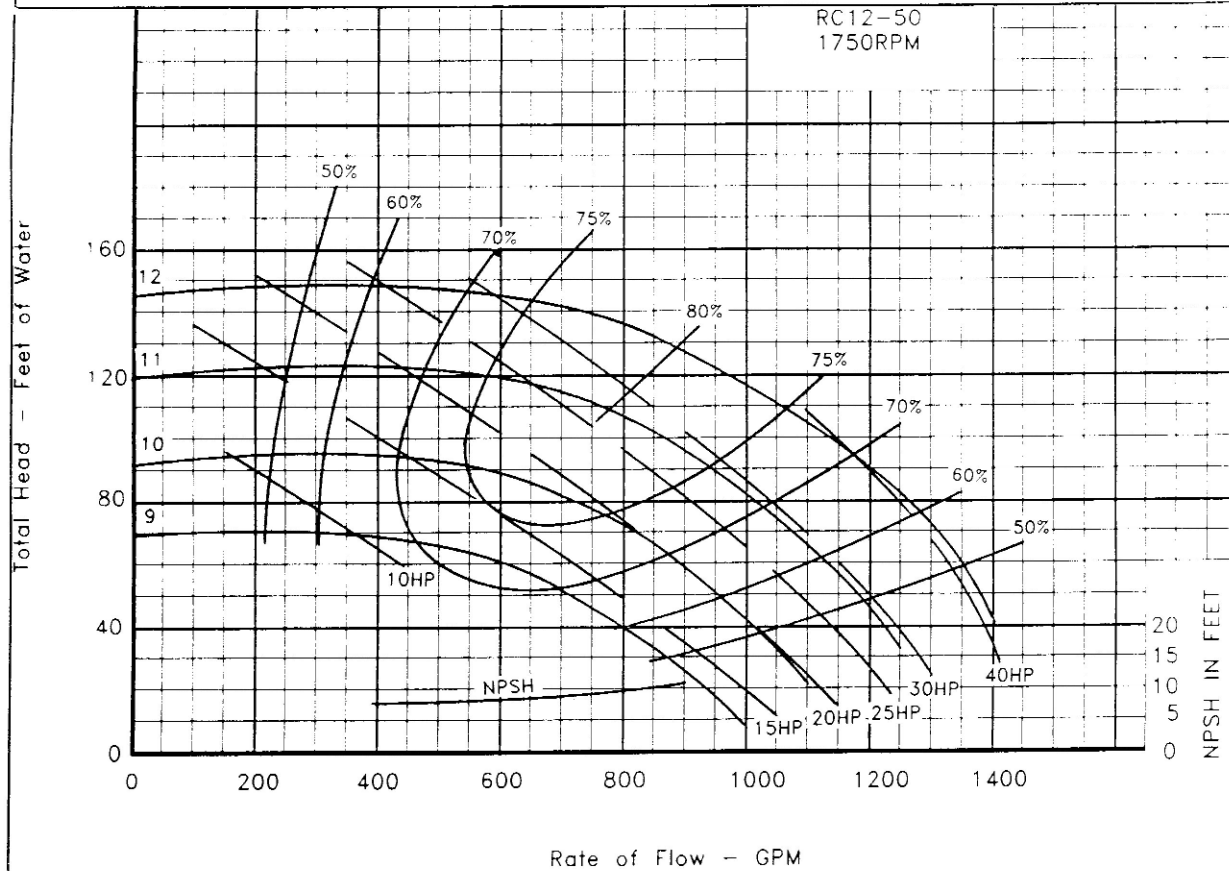
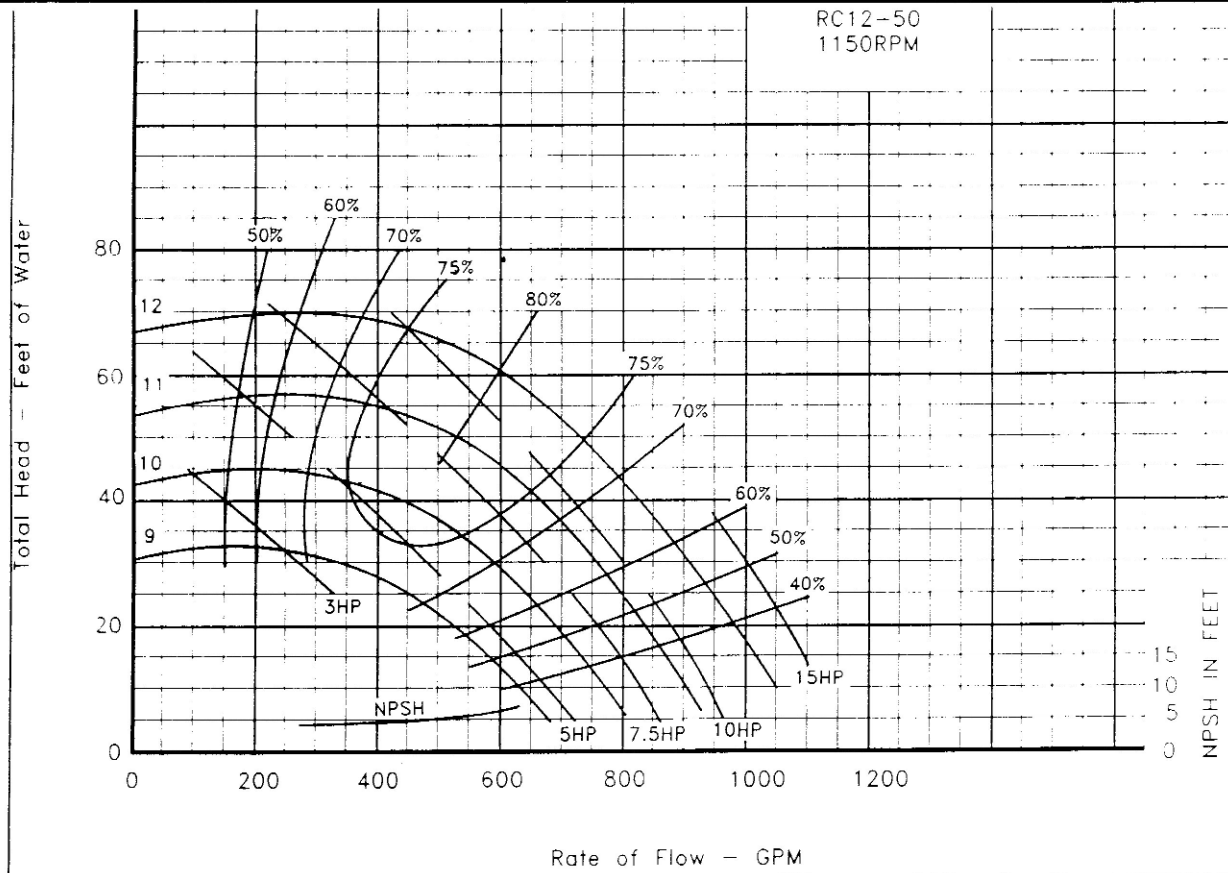

SELECTION CURVES

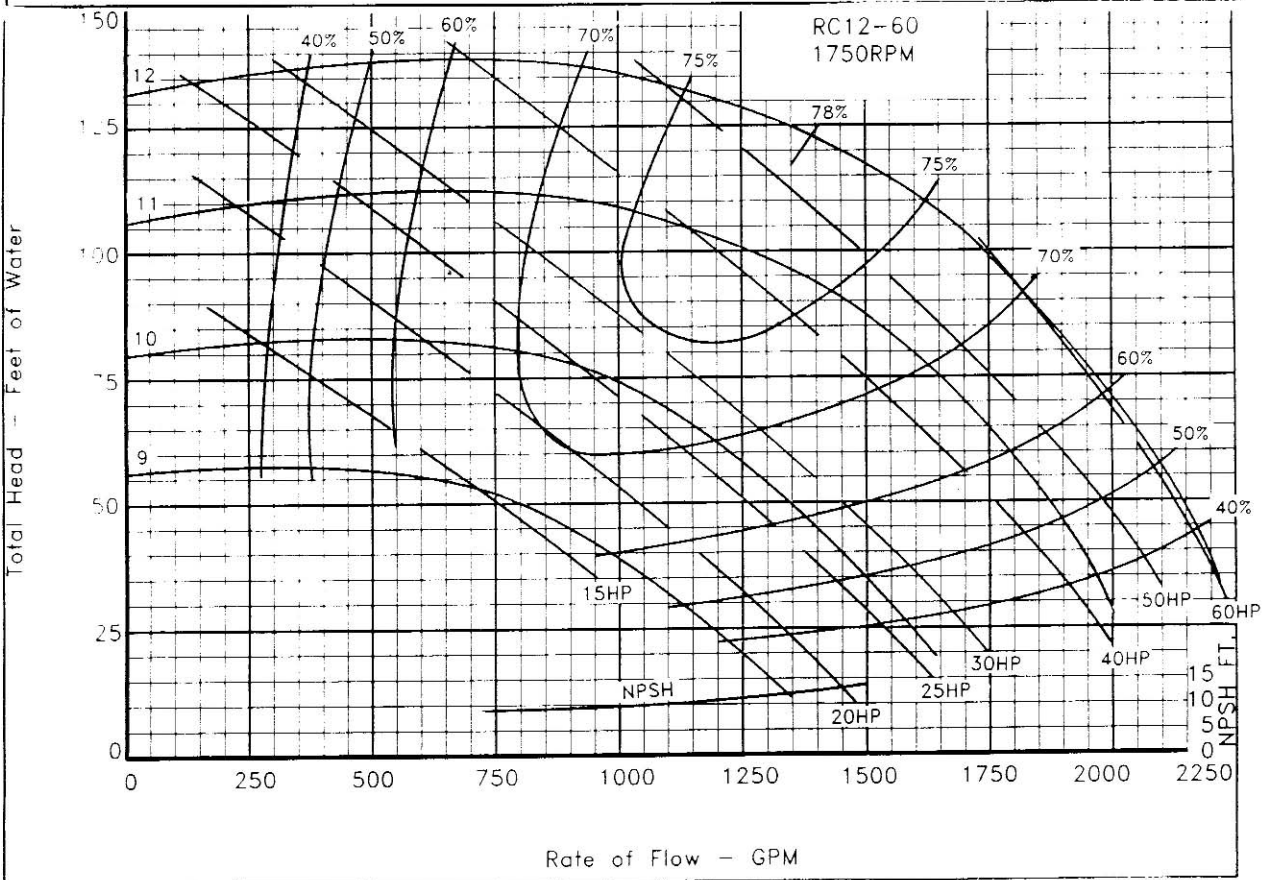
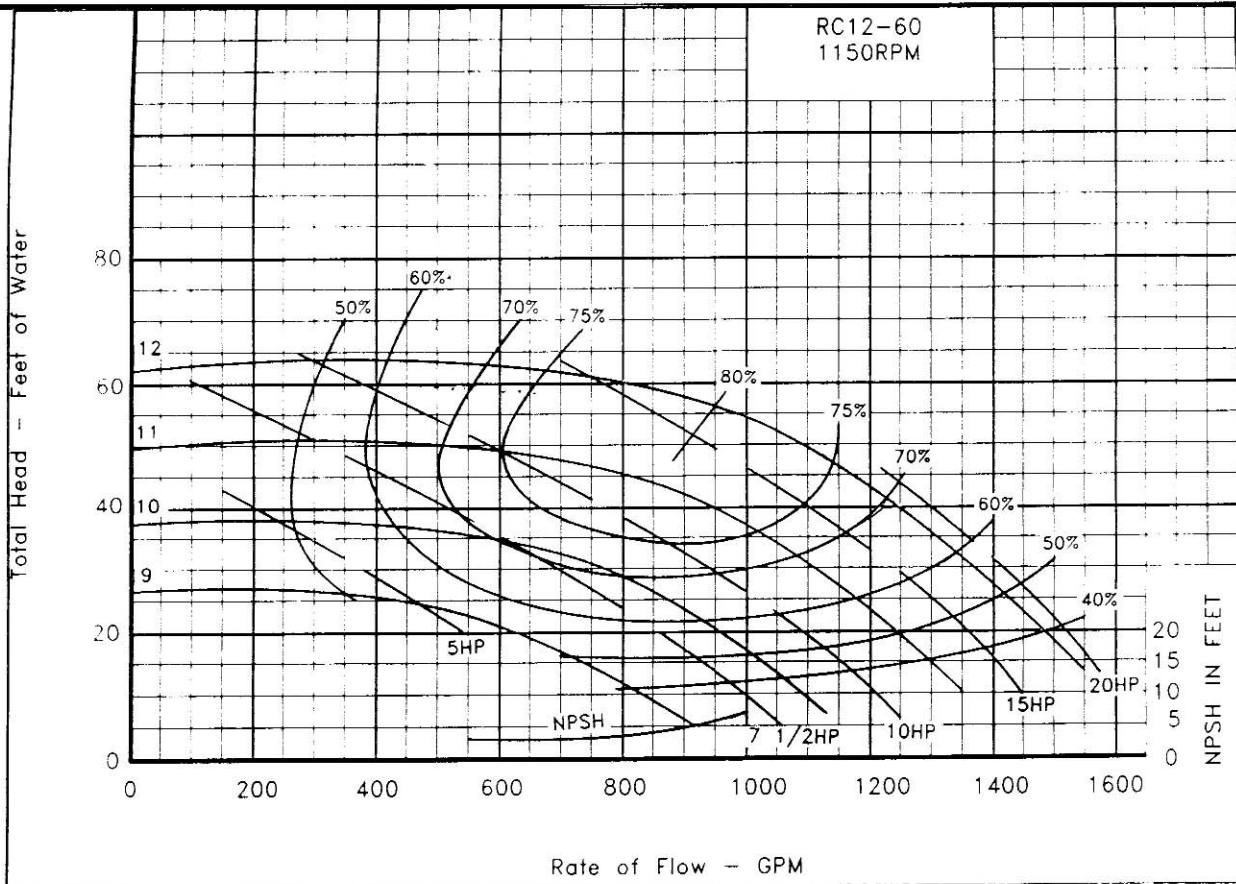

TYPICAL SPECIFICATIONS

- Furnish and install pumps with capacities as shown on plans. Pumps shall be close coupled, single-stage, vertically-split case design, capable of being serviced without disturbing piping connections. Pump volute shall be Class 30 cast iron, and impeller shall be bronze enclosed type, dynamically balanced
- Seal shaft shall be of rotary type and suitable for water temperatures up to 225 degrees Fahrenheit.
- Pumps shall be rated for minimum of 175 PSI working pressure. Casings shall have vent and drain ports at top and bottom casing.
- Motor shall meet NEMA specifications and shall be of the size, voltage and enclosure called for on the plans. It shall have heavy-duty ball bearings, completely adequate for the maximum load for which the motor is designed. Each pump shall be factory tested. It shall then be thoroughly cleaned and painted with at least one coat of high-grade lacquer prior to shipment.
- Each pump shall be checked by the contractor and regulated for proper differential pressure, voltage and amperage draw. This data shall be noted on a permanent tag or label and fastened to pump for owner's reference. Pumps shall be Series RC12 as manufactured by MEPCO.



MARSHALL ENGINEERED PRODUCTS CO.



MARSHALL ENGINEERED PRODUCTS CO.